

Compact Dyna-Star[®] Electric Pump

3A6941L

EN

Provides lubricant flow and pressure to operate both single line and series progressive automatic lubrication systems. For automatic lubrication systems only. For professional use only.

Not approved for use in explosive atmospheres or hazardous (classified) locations.

3500 psi (24.1MPa, 241 bar) Maximum Working Pressure

See page 3 for model information.



Important Safety Instructions

Read all warnings and instructions in this manual and in your injector manual before using the equipment. Save these instructions.

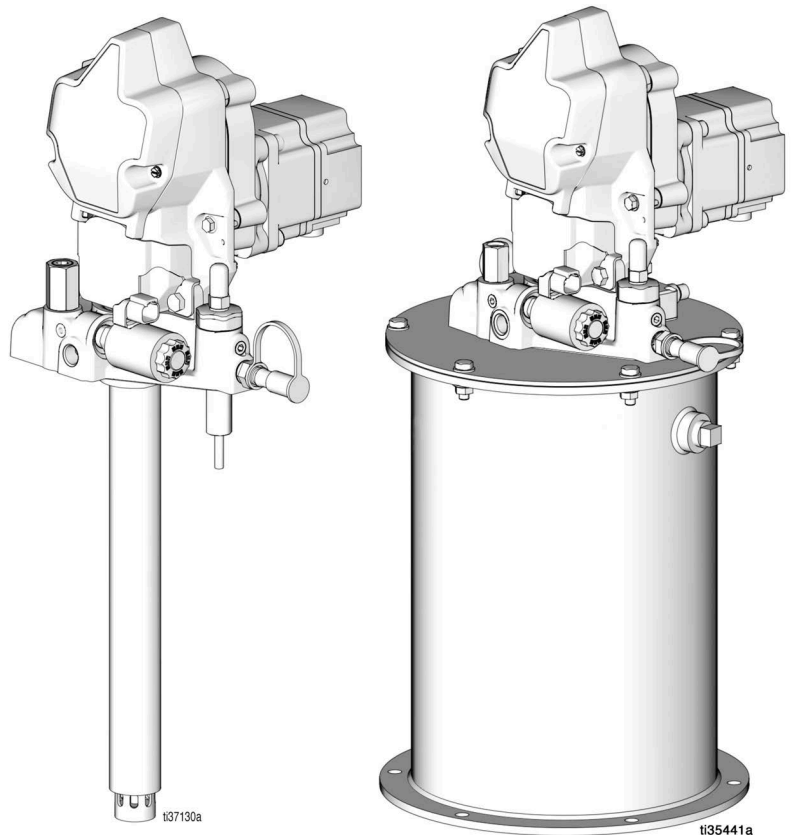

Related Manuals

3A6932 Compact Dyna-Star Auto-Fill Shut Off Kit

3A6998 Compact Dyna-Star 35 lb (5 Gallon) Kit

3A7035 Compact Dyna-Star Pump Cable

333393 Fill Valve

Table of Contents

Pump Model Selection Matrix	3	Troubleshooting	40
Warnings	4	Parts	43
Installation	6	Related Kits	46
Grounding	6	Dimensions: Pump with Tank	48
Pressure Relief Procedure	6	Dimensions: Stand Alone Pump	49
Fuses	7	Dimensions: Stand Alone Pump	50
Mounting	7	Mounting Dimensions: Stand Alone Pump	51
Pump	7	Technical Specifications	52
Single Line Parallel System	7	California Proposition 65	53
Series Progressive System	7	Graco Standard Warranty	54
Inlet and Outlet Components	7	Graco Information	54
Vent Valve	8		
Pressure Relief Valve	8		
Motor Details	8		
Motor Electrical Connection	8		
Typical Installation: Single Line Parallel System ..	9		
Typical Installation: Series Progressive System ..	10		
Typical Wiring: Single Line Parallel Systems ...	11		
Component Identification	12		
Setup	13		
Fill the Tank	13		
Fill Pumps with an Auto-Fill Shut Off (AFSO) ...	15		
Refill the Tank: Pumps with an Auto-fill			
Shut Off (AFSO)	16		
Fill Pumps Without an Auto-fill Shut			
Off (AFSO)	18		
Refill the Tank: Pumps without an Auto-fill Shut			
Off	18		
Operation	20		
Priming the System	20		
Pump Operation Overview	20		
Single Line Parallel System	20		
Series Progressive System	20		
Shutdown	20		
Level Monitoring	21		
Low Level Switch	21		
Level Transducer	22		
Pressure Switch	23		
Pressure Transducer	23		
Maintenance	24		
Disassemble	24		
Reassemble	31		

Pump Model Selection Matrix

Pump models are made up of a six-digit part number. The first two digits are fixed alpha characters, while the remaining four are chosen from the matrix below. Select an item from each column to fill in the model number for ordering.





1		2		3		4	
Pump Description		Metering System Feedback		Tank		Tank Accessories	
1	12L / 35 lb. Bucket Length, 24 VDC	0	Single Line Progressive, no vent valve, no pressure reporting	0	No Tank, Bare Pump	0	No Tank, Bare Pump
2	20L Tank Length, 24 VDC	1	Vent Valve, No Pressure Reporting	1	12L Steel Tank with Follower Plate	1	Low Level Switch
3	60 lb. Tank Length, 24 VDC	2	Vent Valve, Pressure Switch	2	20L Steel Tank with Follower Plate	2	Level Transducer
		3	Vent Valve, Pressure Transducer	3	35 lb. Plastic Bucket Kit	3	Auto-Fill Shut Off and Low Level Switch
				4	12 L Steel Tank with no Follower Plate	4	Auto-Fill Shut Off, Level Transducer
				5	20 L Steel Tank with no Follower Plate		
				6	60 lb. Steel Tank with Follower Plate		
				7	60 lb. Steel Tank with no Follower Plate		





NOTE: Some pump configurations are not available. Contact Graco customer service or your local Graco distributor for assistance.

Warnings

The following warnings are for the setup, use, grounding, maintenance, and repair of this equipment. The exclamation point symbol alerts you to a general warning and the hazard symbols refer to procedure-specific risks. When these symbols appear in the body of this manual or on warning labels, refer back to these Warnings. Product-specific hazard symbols and warnings not covered in this section may appear throughout the body of this manual where applicable.



 <h1 style="margin: 0;">WARNING</h1>	
	<p>FIRE AND EXPLOSION HAZARD</p> <p>When flammable fluids are present in the work area, such as gasoline and windshield wiper fluid, be aware that flammable fumes can ignite or explode. To help prevent fire and explosion:</p> <ul style="list-style-type: none"> • Use equipment only in well ventilated area. • Eliminate all ignition sources, such as cigarettes and portable electric lamps. • Ground all equipment in the work area. • Keep work area free of debris, including rags and spilled or open containers of solvent and gasoline. • Do not plug or unplug power cords or turn lights on or off when flammable fumes are present. • Use only grounded hoses. • Stop operation immediately if static sparking occurs or you feel a shock. Do not use equipment until you identify and correct the problem. • Keep a working fire extinguisher in the work area.
	<p>SKIN INJECTION HAZARD</p> <p>High-pressure fluid from dispensing device, hose leaks, or ruptured components will pierce skin. This may look like just a cut, but it is a serious injury that can result in amputation. Get immediate surgical treatment.</p> <ul style="list-style-type: none"> • Do not point dispensing device at anyone or at any part of the body. • Do not put your hand over the fluid outlet. • Do not stop or deflect leaks with your hand, body, glove, or rag. • Follow the Pressure Relief Procedure when you stop dispensing and before cleaning, checking, or servicing equipment. • Tighten all fluid connections before operating the equipment. • Check hoses and couplings daily. Replace worn or damaged parts immediately.

WARNING

 	<p>EQUIPMENT MISUSE HAZARD</p> <p>Misuse can cause death or serious injury.</p> <ul style="list-style-type: none"> • Do not operate the unit when fatigued or under the influence of drugs or alcohol. • Do not exceed the maximum working pressure or temperature rating of the lowest rated system component. See in all equipment manuals. • Use fluids and solvents that are compatible with equipment wetted parts. See in all equipment manuals. Read fluid and solvent manufacturer’s warnings. For complete information about your material, request Safety Data Sheet (SDS) from distributor or retailer. • Turn off all equipment and follow the Pressure Relief Procedure when equipment is not in use. • Check equipment daily. Repair or replace worn or damaged parts immediately with genuine manufacturer’s replacement parts only. • Do not alter or modify equipment. Alterations or modifications may void agency approvals and create safety hazards. • Make sure all equipment is rated and approved for the environment in which you are using it. • Use equipment only for its intended purpose. Call your distributor for information. • Route hoses and cables away from traffic areas, sharp edges, moving parts, and hot surfaces. • Do not kink or over bend hoses or use hoses to pull equipment. • Keep children and animals away from work area. • Comply with all applicable safety regulations.
 	<p>MOVING PARTS HAZARD</p> <p>Moving parts can pinch, cut or amputate fingers and other body parts.</p> <ul style="list-style-type: none"> • Keep clear of moving parts. • Do not operate equipment with protective guards or covers removed. • Pressurized equipment can start without warning. Before checking, moving, or servicing equipment, follow the Pressure Relief Procedure and disconnect all power sources.
	<p>PERSONAL PROTECTIVE EQUIPMENT</p> <p>Wear appropriate protective equipment when in the work area to help prevent serious injury, including eye injury, hearing loss, inhalation of toxic fumes, and burns. Protective equipment includes but is not limited to:</p> <ul style="list-style-type: none"> • Protective eyewear, and hearing protection. • Respirators, protective clothing, and gloves as recommended by the fluid and solvent manufacturer.

Installation

Grounding

				
<p>The equipment must be grounded to reduce the risk of static sparking. Static sparking can cause fumes to ignite or explode. Grounding provides an escape wire for the electric current.</p>				

To ground the pump: remove the ground screw (Z) located on the back of the gear box and insert it through the eye of the ring terminal (W) at end of ground wire (Y). Fasten the ground screw (Z) back onto the pump and tighten securely. Connect the other end of the ground wire (Y) to a true earth ground (FIG. 1). To order a ground and wire clamp, order Part 222011.

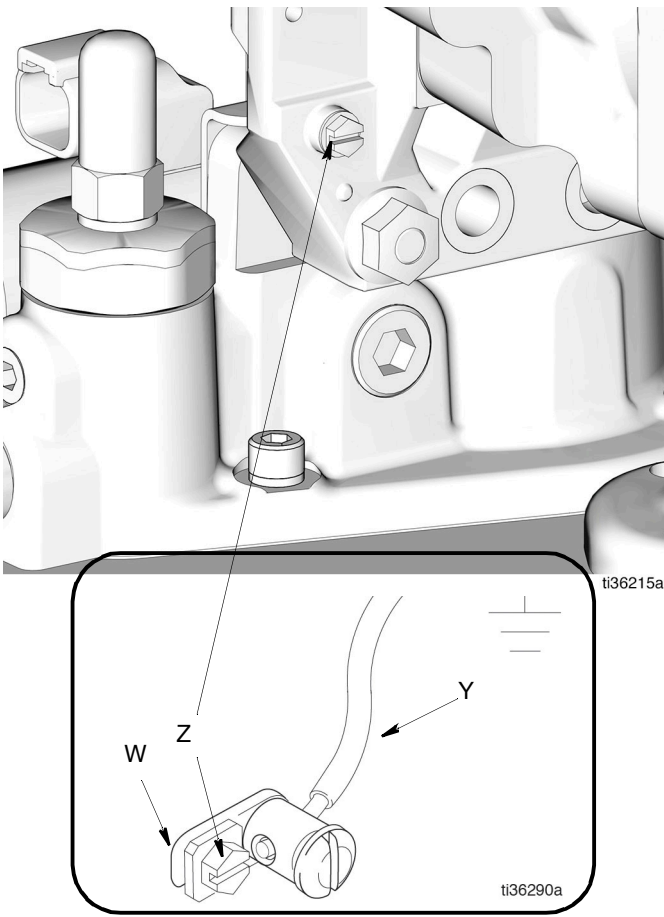









FIG. 1

Pressure Relief Procedure

 Follow the Pressure Relief Procedure whenever you see this symbol.

				
				
<p>This equipment stays pressurized until pressure is manually relieved. To help prevent serious injury from pressurized fluid, such as skin injection, splashing fluid and moving parts, follow the Pressure Relief Procedure when you stop dispensing and before cleaning, checking, or servicing the equipment.</p>				

To relieve pressure in the system, use two wrenches working in opposite directions on the pump outlet fitting to slowly loosen the fitting only until no more lubricant or air is leaking from the fitting (FIG. 2).

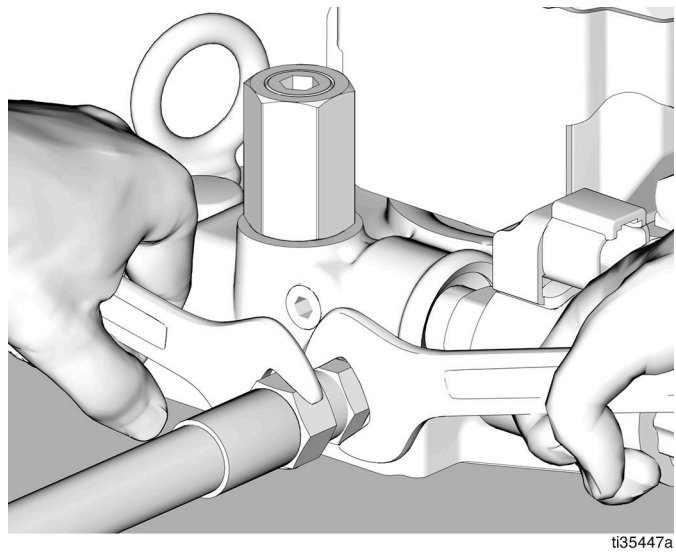

FIG. 2

Fuses

NOTICE

Fuses (user supplied) are required on all models. To avoid equipment damage:

- Never operate the pump without a fuse installed.
- A fuse of the correct voltage and amperage must be installed in line with the power entry to the system. Graco recommends using a 10A time delay fuse.

3. Connect a high pressure lubricant supply line (D) to the lubricant outlet connection (P or AC).
4. Connect all electrical connections. See **Typical Wiring: Single Line Parallel Systems** diagram, page 11.
5. Ground the system. See **Grounding** instructions, page 6.

Mounting

<p>LIFTING HAZARD This equipment is heavy. Lifting or moving heavy equipment incorrectly can cause serious injury such as muscle strain or back injuries. To avoid injury:</p> <ul style="list-style-type: none"> • Do not lift or move this equipment without assistance. • Always use a lifting device secured to the pump when moving or installing this equipment. See Technical Specifications, page 52 for pump weight. 				

NOTE: Upper case letters used in the following instructions refer to **Typical Installation: Single Line Parallel System** (FIG. 5), **Typical Installation: Series Progressive System** (FIG. 6), **Typical Wiring: Single Line Parallel Systems** (FIG. 7), and **Component Identification** (FIG. 8) diagrams starting on page 9.

Securely mount and ground the unit before operation.

1. Mount the tank (K) on a sturdy, flat surface with user-provided bolts. Install so that the fill port (F) and the lubricant outlet connection (P or AC) are easily accessible after installation.

<p>The breather (J) vents the tank to the atmosphere. If it is plugged the tank will over-pressurize and rupture. Be sure the breather is not plugged before filling the pump.</p>				

2. Connect the controller (F) (if used).

Pump

The pump provides lubricant flow and pressure to operate an automatic lubrication system.

Single Line Parallel System

The pump requires an electrical power supply and a timed signal from a lubrication controller (F). The pump provides lubricant flow and pressure to operate the injectors (E), and vents the injector system to reset the injectors.

Series Progressive System

The pump requires an electrical power supply and a timed signal from a lubrication controller (F). The pump provides lubrication flow and pressure to operate metering devices (AD).

Inlet and Outlet Components

<p>COMPONENT RUPTURE HAZARD The maximum working pressure of the inlet and outlet components in the system vary. Over-pressurizing an inlet or outlet can cause components to rupture, potentially resulting in serious injury such as skin injection or injury from splashing fluid. To reduce the risk of component rupture:</p> <ul style="list-style-type: none"> • Be sure to know the maximum working pressure of each inlet and outlet component in the system. • Never exceed the maximum working pressure of the inlet and outlet components. 				

Vent Valve

The vent valve (L) reduces system pressure in Series Single Line system and resets the injectors.

Pressure Relief Valve

The pump design includes a self-contained pressure relief valve (N). When needed, the valve relieves pressure back into the pump tank (K).

Motor Details

The pump (B) is driven by a 24 V DC brushless motor (1) with a built-in controller. The motor LED flashes multiple times during start up and stays on during operation. Refer to **Troubleshooting**, page 40 for more information.

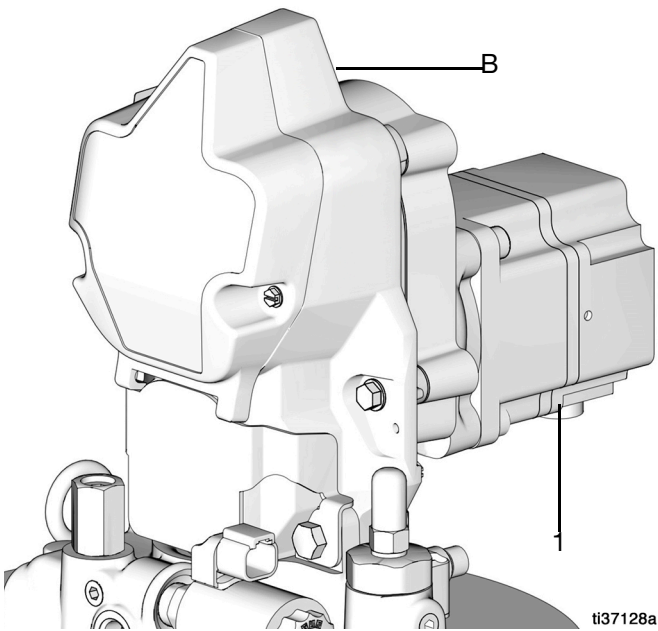

FIG. 3

Motor Electrical Connection

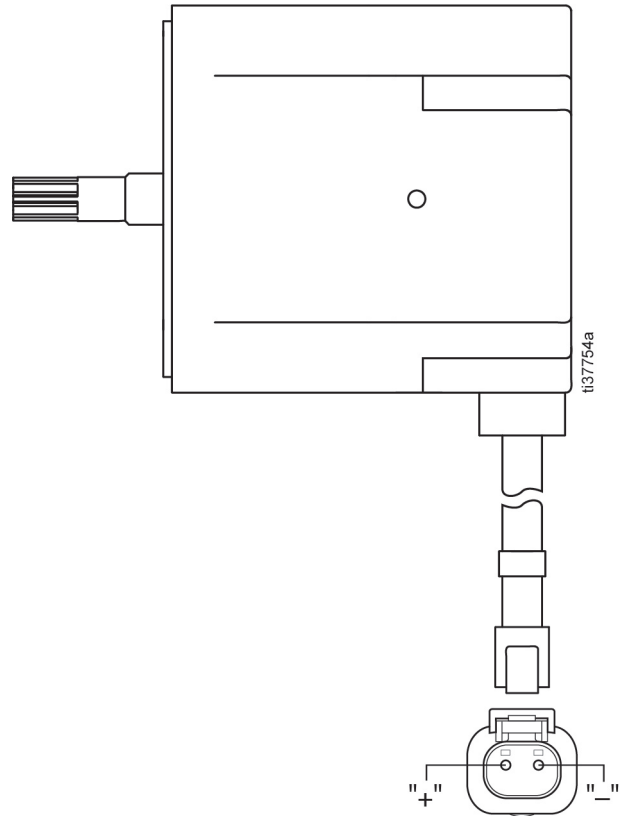

FIG. 4

Typical Installation: Single Line Parallel System

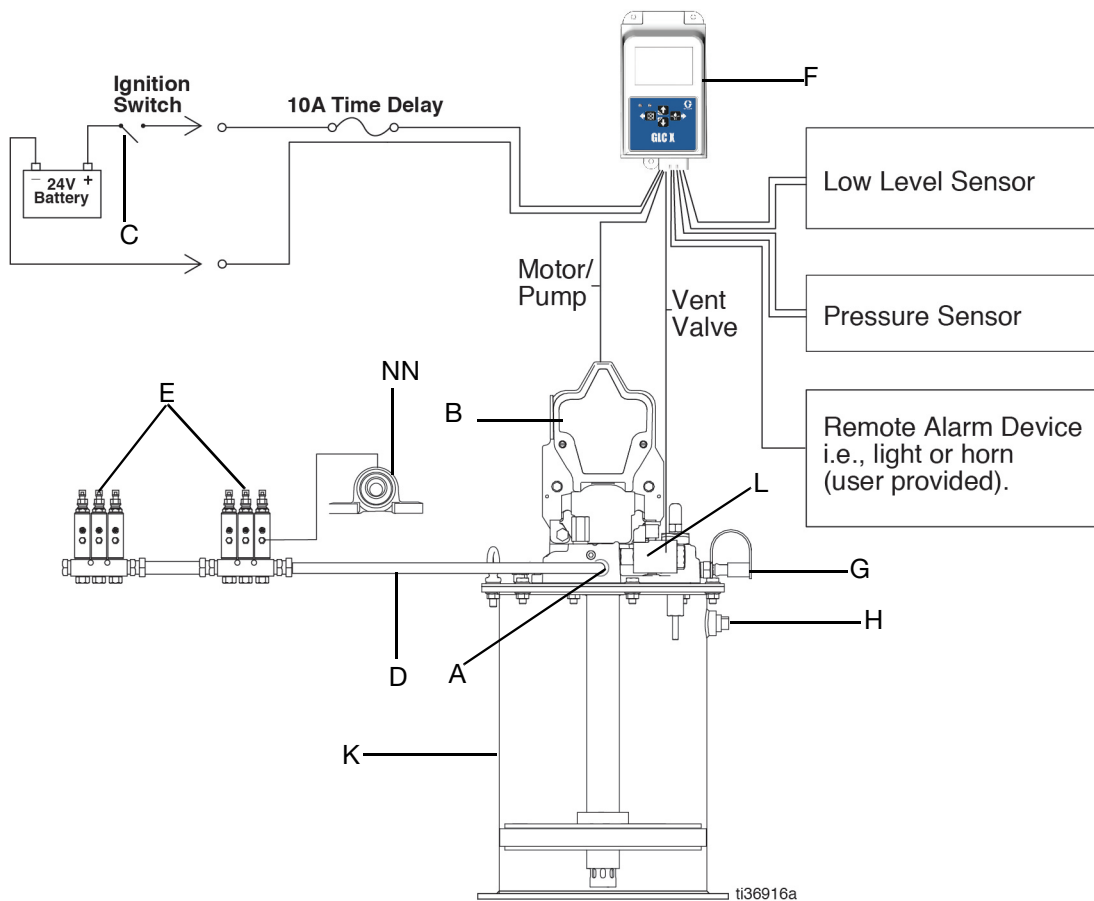

FIG. 5

Key:

- A Lubricant output connection*
- B Pump
- C Ignition switch*
- D High-pressure lubricant supply lines*
- E Injector banks*
- F Lubrication controller*
- G Fill port
- H Overflow port
- K Tank
- L Vent Valve
- NN Bearing*

*User provided

Typical Installation: Series Progressive System

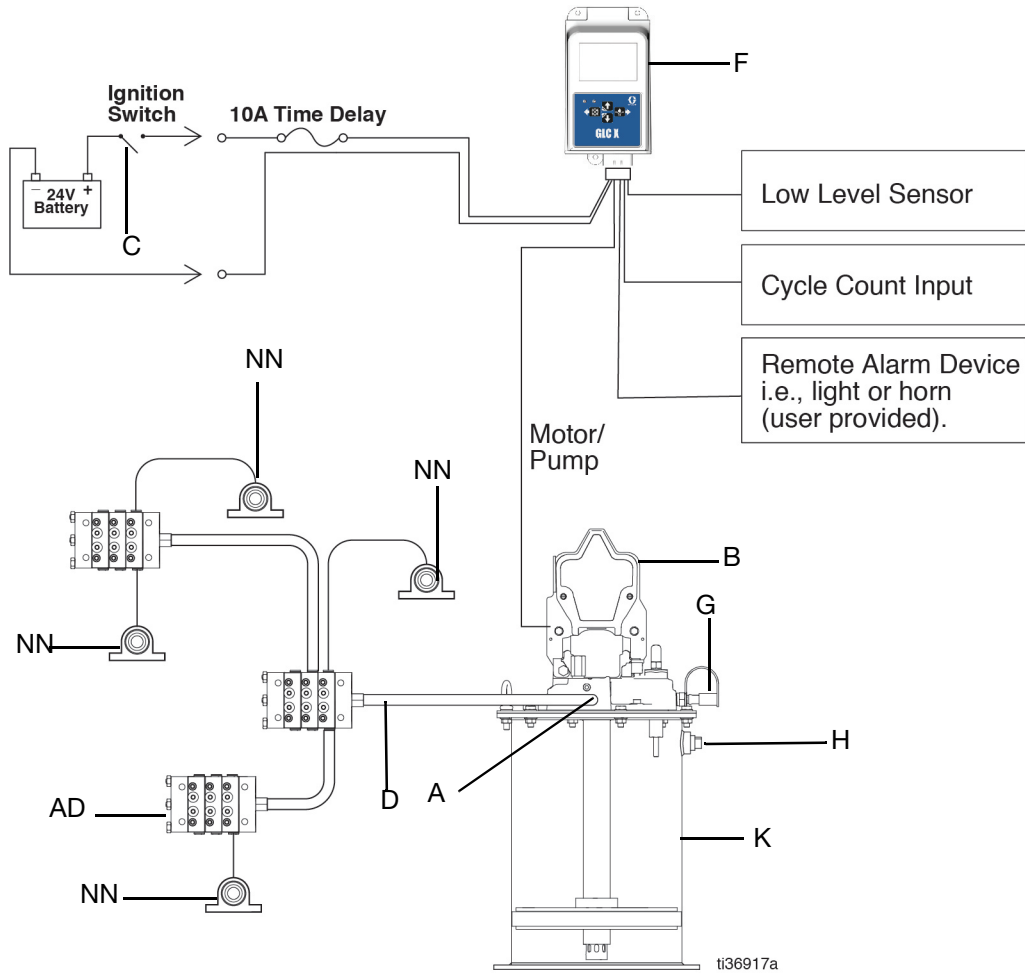

FIG. 6

Key:

- A Lubricant output connection*
- B Pump
- C Ignition switch*
- D High-pressure lubricant supply lines*
- F Lubrication controller*
- G Fill port
- H Overflow port
- K Tank
- NN Bearing*
- AD Metering device*

*User provided

Typical Wiring: Single Line Parallel Systems

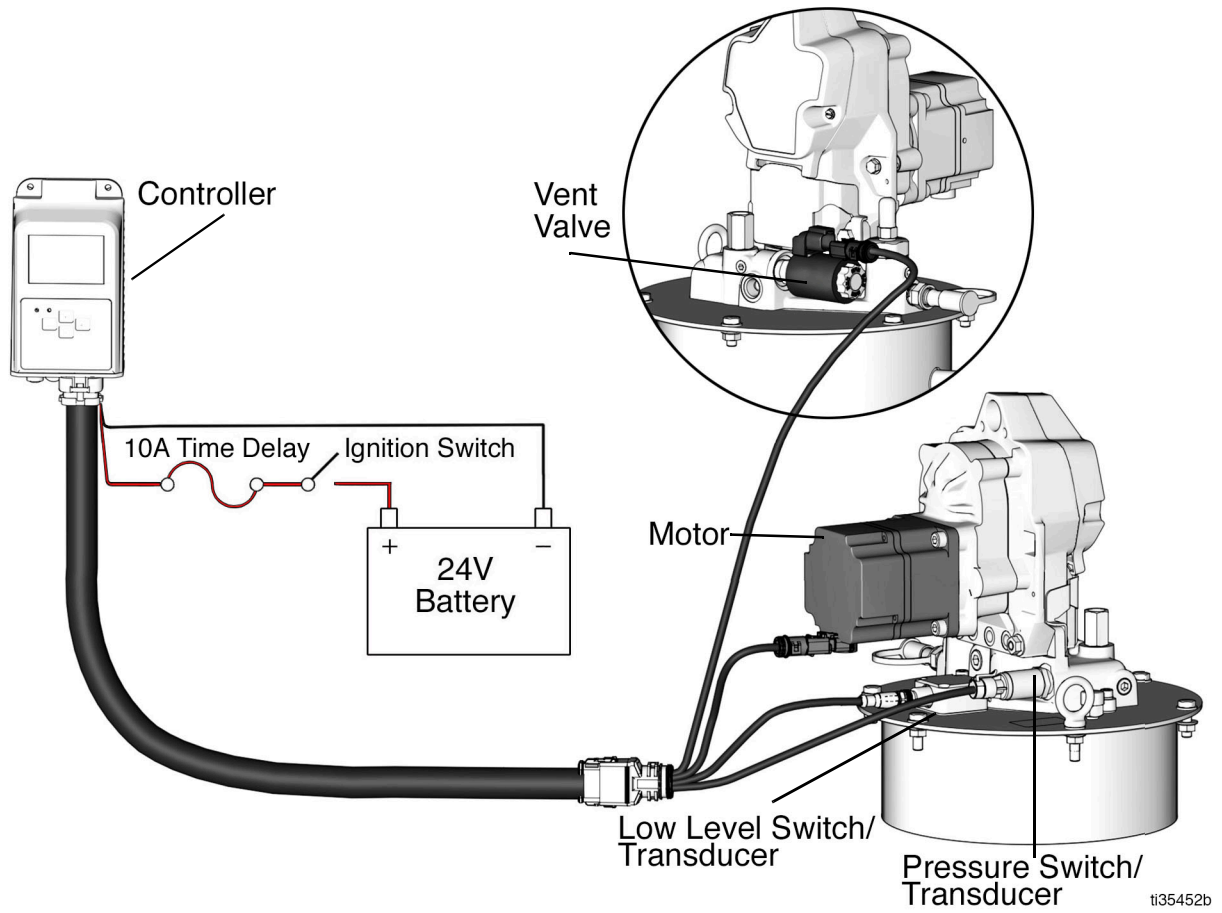

FIG. 7

t135452b

Component Identification

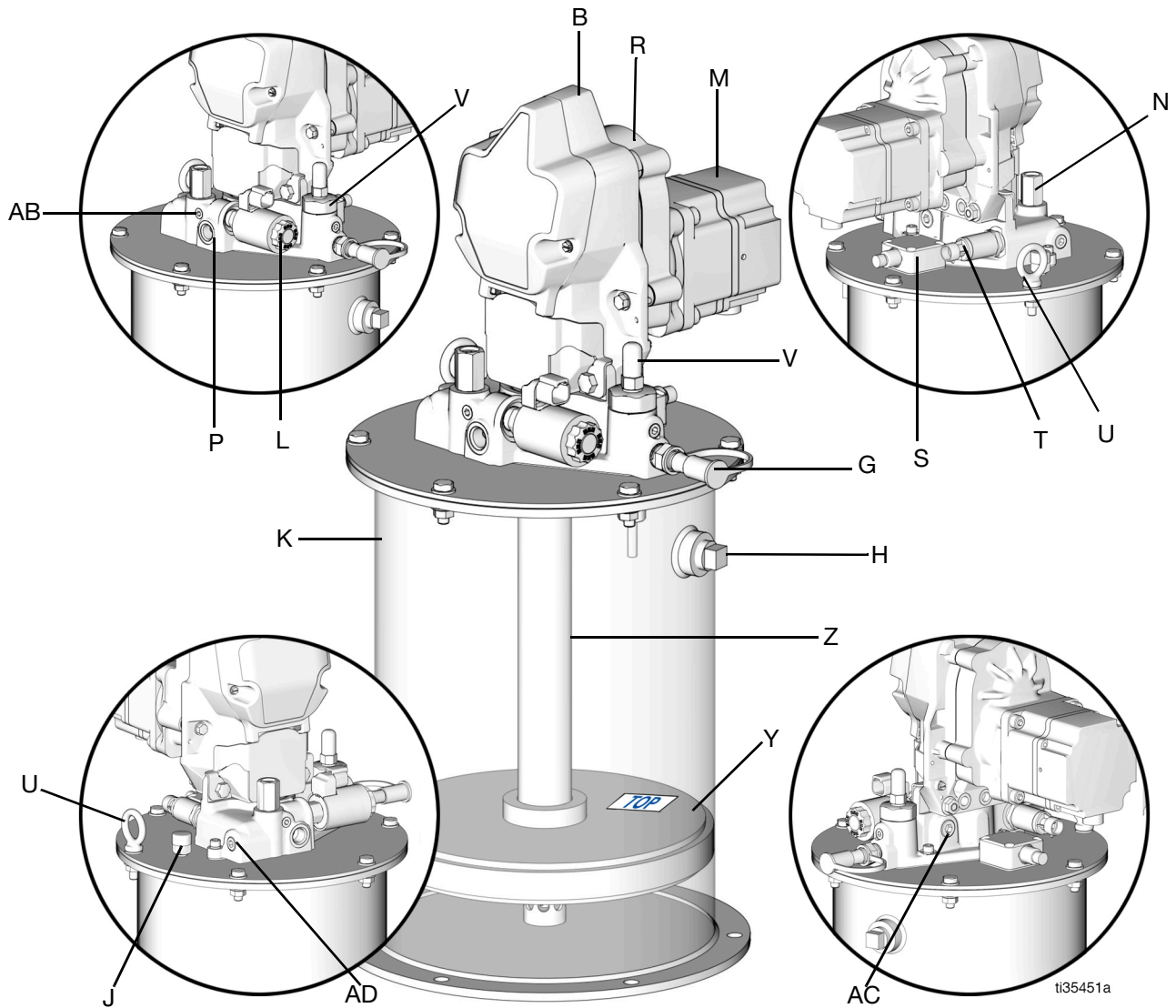

Fig. 8

Key:(Figure 6)

- B Pump
- G Fill port and cover
- H Overflow port
- J Breather
- K Tank
- L Vent valve
- M Motor
- N Pressure relief valve
- P Outlet (3/8 in. NPT)
- R Gear box
- S Low level switch or level transducer

- T Pressure switch or transducer
- U Lift ring
- V Auto-fill shut off (AFSO) (optional)
- Y Follower plate
- Z Tube-in-tube
- AB Plug to check venting / pressure relief
- AC Refill vent plug or refill pressure relief
- AD Outlet (1/4 in. NPT) (optional)

Setup

Fill the Tank

The fill port is used for filling and refilling the tank for pumps with or without auto-fill.

Fill the tank through the fill port (FIG. 9).

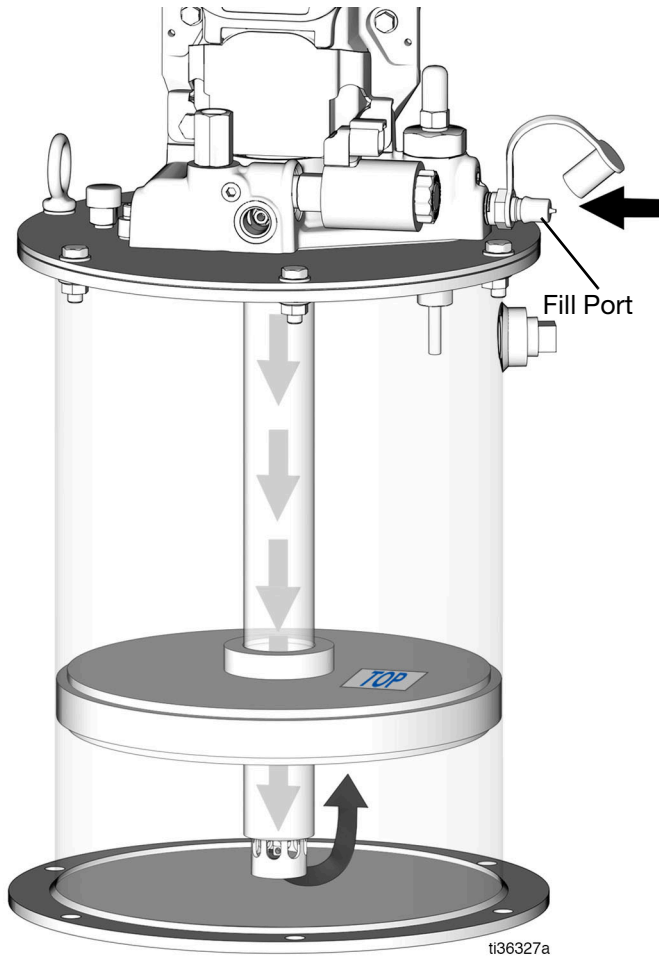

FIG. 9:

ti36327a

Auto-Fill Shut Off: When grease is added, the follower plate is pushed upward and closes the flow path. (FIG. 10).

Non-Auto-Fill Shut Off: When grease is added, the follower plate is pushed upward. When the tank is full, the grease will begin to flow out of the overflow port (H).

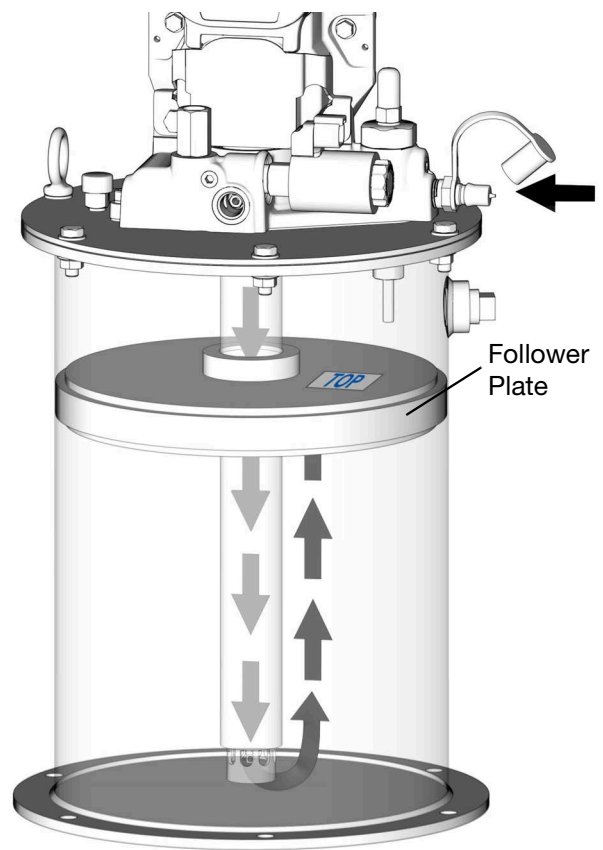

FIG. 10

Setup

Always fill the pump through the fill port to expel any air from the tube-in-tube (FIG. 11).

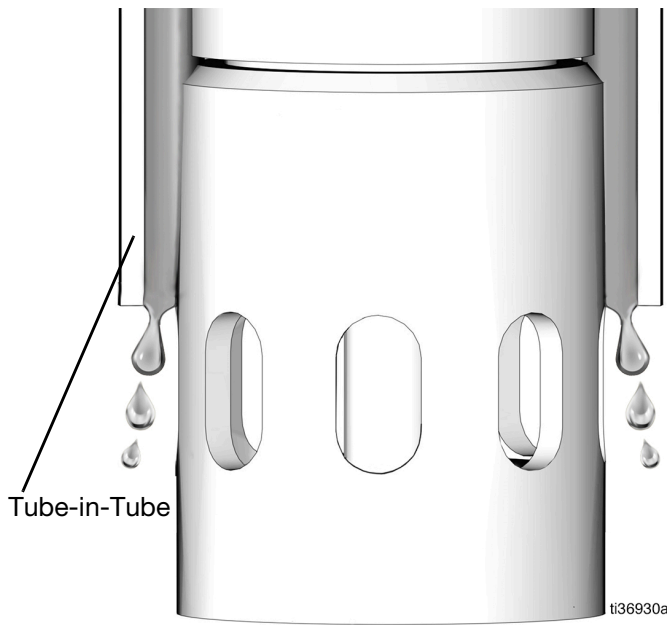

FIG. 11

Always use the follower plate to prime the pump for grease NLGI 1, NLGI 2, and for cold pumping applications.

Note: The auto-fill shut off requires using a follower plate.

The follower plate should not be used with oil and low viscous grease applications. The follower plate may sink in these lubricants and block the pump inlet.

Fill Pumps with an Auto-Fill Shut Off (AFSO)

NOTE: The remote filling station pump stalls (dead-heads) when the tank is full. If the pump does not stall (dead-head) there is a leak in the system.

NOTE: The refill pump stall pressure (dead-heads pressure) should not exceed 5000 psi (34.5 MPa, 345 bar). Adjust the air pressure based upon the air-operated fill pump ratio. For example, if using a 50:1 pump, the inlet air pressure for the refill pump must not exceed 100 psi (0.69 MPa, 6.9 bar).

NOTE: The fill pump pressure can be as high as 2000 psi, depending upon the lengths and diameters of Refilling line (GG) and Supply hose (JJ). Graco recommends using a 36:1 ratio, or higher, air operated fill pump.

NOTE: Use fill valve P/N 77X542 (as shown in FIG. 12) to protect from overpressure, or use safety relief valve set at 5000 psi (34.5 MPa, 345 bar) in the refilling line (GG).

NOTICE

Never allow the pump to run dry of the fluid being pumped to avoid pump damage.

NOTICE

If the refilling pump runs dry it pumps air into the pump and may cause damage. Always make sure that there is enough lubricant in the refilling pump station.

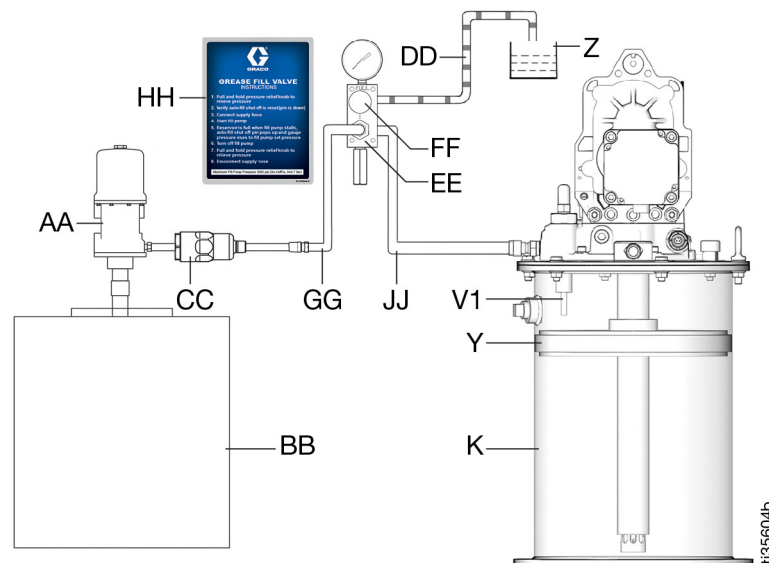

FIG. 12

Key:

- AA Remote fill station pump*
- BB Remote fill station tank*
- CC Filter*
- DD Pressure relief line*
- EE Fill valve* [Graco Part No. 77X542]
- FF Fill valve pressure relief knob* [Part of Fill Valve 77X542]
- GG Refilling line*
- HH Instruction label* [Included with Fill Valve 77X542]
- JJ Supply hose*
- K Tank
- V Auto-Fill Shut Off
- V1 Auto-Fill Shut Off valve pin
- Y Follower plate
- Z Fluid vent container

*User supplied



COMPONENT RUPTURE HAZARD

The maximum working pressure of each component in the system may not be the same. To reduce the risk of over pressurizing any component in the system, know the maximum working pressure of each component. **Never** exceed the maximum working pressure of the lowest rated component in the system. Over pressurizing can result in rupture, potentially resulting in serious injury from skin injection or splashing fluids.

Regulate pressure to the pump so that no fluid line, component or accessory is over pressurized.

Setup

The auto-fill shut off (V) is used to refill the grease tank (K) in an automatic lubrication system. When the grease level in the tank is full, the auto-fill shut off automatically ends the filling operation.

Always fill the tank (K) to full during refilling.

As grease is added to the tank (K), the follower plate (Y) is pushed to the top of the tank (K) and pushes up the valve pin (V1) which closes the inlet fluid path. Pin (V2) pops up when the tank is full (FIG. 13).

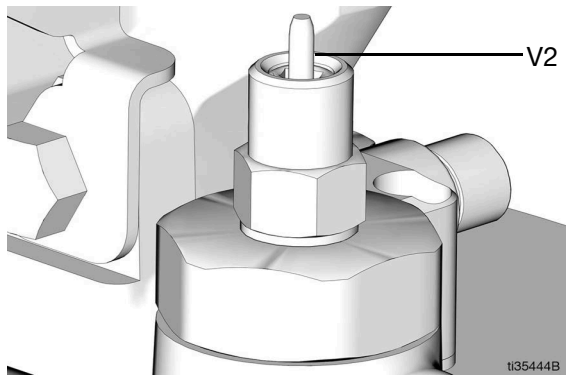
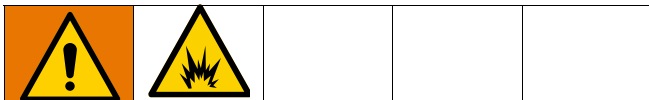

FIG. 13

When the fluid refilling path closes, the refilling line (GG) pressurizes and brings the remote fill station pump (AA) to a pressurized stall condition.

Note: The operator must monitor the system during filling of the tank to prevent any accidental fluid overflow.

Refill the Tank: Pumps with an Auto-fill Shut Off (AFSO)



The breather (J) vents the tank to the atmosphere. If it is plugged the tank will over-pressurize and rupture, potentially causing serious injury. Be sure the breather is not plugged before filling the pump.

1. Pull and hold the fill valve pressure relief knob (FF) long enough to relieve line pressure between the fill valve (EE) and the auto-fill shut off valve (V).

2. Verify the auto-fill shut off pin (V2) is down, indicating it is reset (FIG. 14).

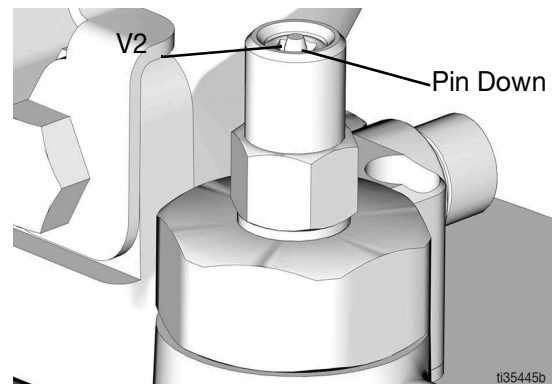

FIG. 14

3. Remove the dust cover (DC) from the fill coupler (FC) on the fill valve (EE) (FIG. 15).

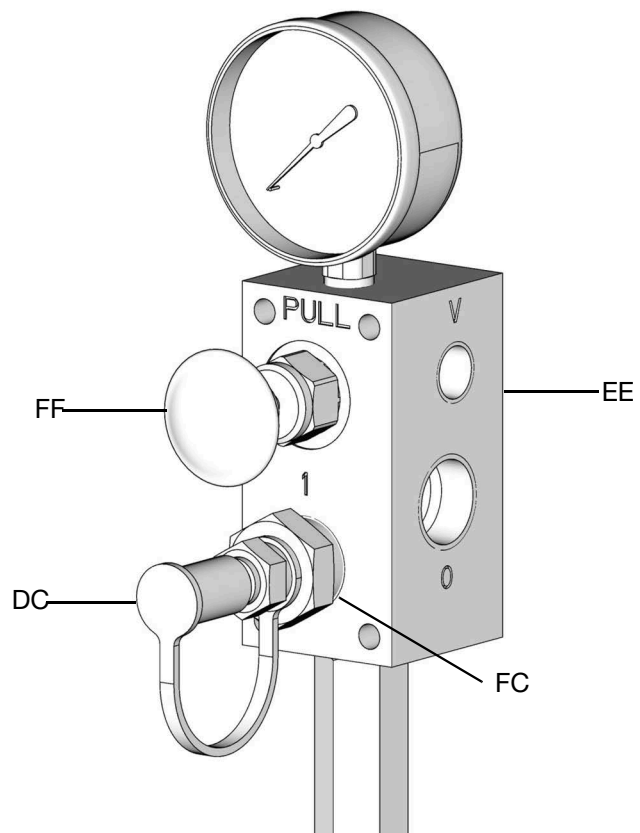

FIG. 15

- Connect the refilling line (GG) between the remote fill station pump (AA) and fill coupler (FC) port marked with an "I" (FIG. 15).

NOTICE

To prevent damage to the unit:

- Check breather (J) vent for proper operation before filling the tank (K).
- Do not fill tank (K) beyond the overflow port (H).
- Do not use the breather (J) as a port to fill the tank.

- Start the remote fill station pump (AA).
- When the tank (K) is filled:
 - The remote fill station pump (AA) stalls (dead-heads),
 - the auto-fill shut off pin (v2) pops up as shown in FIG. 16,
 - The pressure gauge needle rises to the fill pump's set pressure.

Note: If the pump does not stall (dead-head) there is a leak in the system.

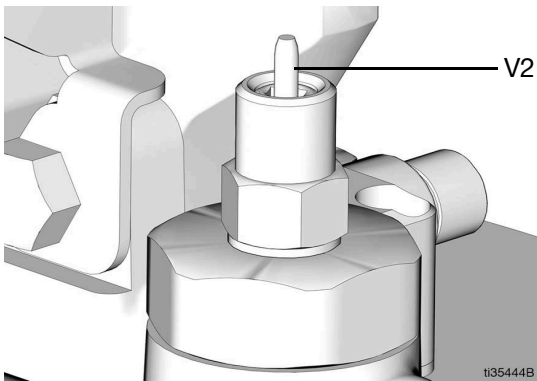

FIG. 16

- Turn off the remote fill station pump (AA).
- Pull and hold the fill valve pressure relief knob (FF) long enough to relieve line pressure between fill valve (EE) and Auto-fill Shut Off Valve (V) and between remote fill station pump (AA) and fill valve (EE).
- Grease collected in a container to vent the pressure from the pressure relief line (DD) should be disposed of following local regulations.

Note: The length of time it takes to vent the pressure varies depending on the system design and installation. In some installations it may be necessary to repeat Step 8 to ensure pressure is relieved.

- Disconnect the refilling line (GG) from the fill coupler (FC) (FIG. 15).
- Replace the dust cover (DC) over the fill coupler (FC).

Fill Pumps Without an Auto-fill Shut Off (AFSO)

Note: The fill pump pressure can be as high as 2000 psi, depending upon the length and diameter of Supply hose (JJ). Graco recommends using a 36:1 ratio, or higher, air operated fill pump.

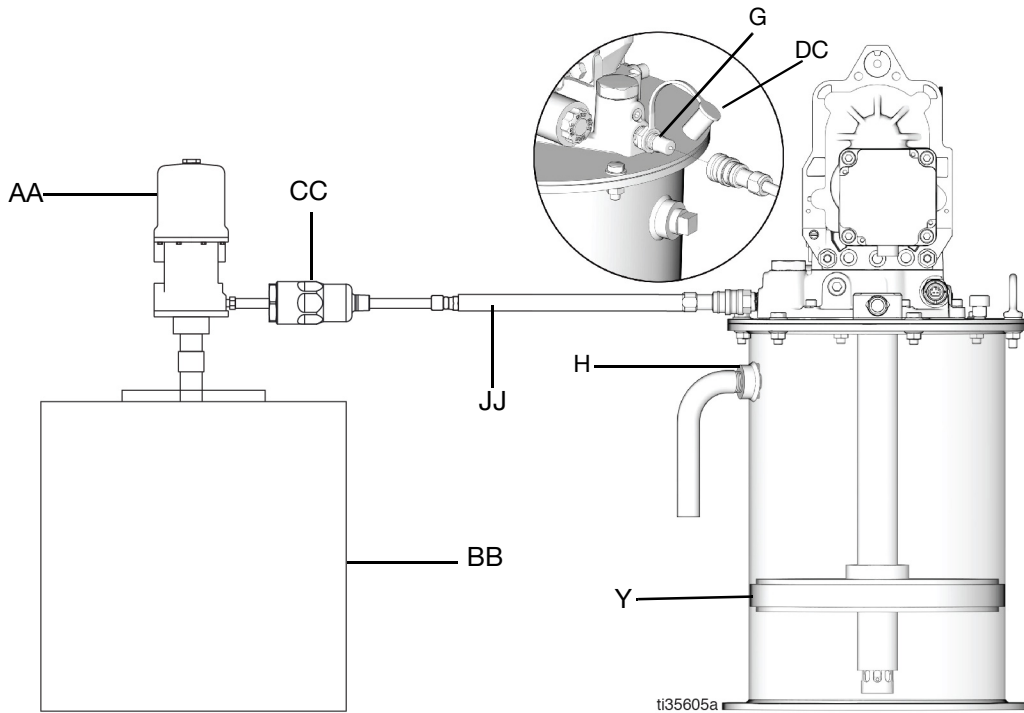

FIG. 17

Key:

- AA Remote fill station pump*
- BB Remote fill station tank*
- CC Filter*
- DC Dust cap
- G Fill port
- JJ Supply hose*
- H Overflow port
- Y Follower plate

*User supplied

Refill the Tank: Pumps without an Auto-fill Shut Off

Do not insert your finger into the overflow port while filling a tank equipped with a follower plate. Injury or amputation could result.			

COMPONENT RUPTURE HAZARD			
The maximum working pressure of each component in the system may not be the same. To reduce the risk of over pressurizing any component in the system, know the maximum working pressure of each component. Never exceed the maximum working pressure of the lowest rated component in the system. Over pressurizing can result in rupture, potentially resulting in serious injury from skin injection or splashing fluids.			
Regulate pressure to the pump so that no fluid line, component or accessory is over pressurized.			

1. Connect the lubricant supply hose (JJ) from the remote filling station pump (AA) to the fill port (G) (FIG. 18).

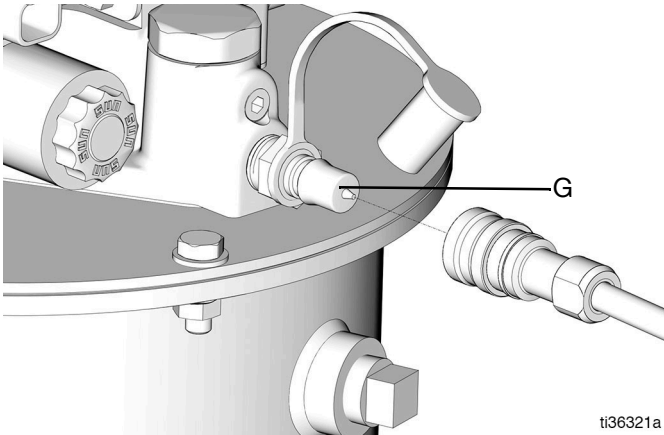

FIG. 18

t36321a

<p>The breather (J) vents the tank to the atmosphere. If it is plugged the tank will over-pressurize and rupture, potentially causing serious injury. Be sure the breather is not plugged before filling the pump.</p>					

2. Slowly turn on the supply lubricant until the level of lubricant reaches the overflow port (H). When the tank (K) is full (or overfilled) grease will flow out of the overflow port. (H).

Note: For pump tanks (K) with a follower plate (Y), fill the tank until the follower plate reaches the overflow port (H) and grease flows out.

NOTICE
<p>To prevent damage to the unit:</p> <ul style="list-style-type: none"> • Check breather (J) vent for proper operation before filling the tank (K). • Do not fill tank (K) beyond the overflow port (H). • Do not use the breather (J) as a port to fill the tank.

Operation

Note: Upper case letters used in the following instructions refer to **Component Identification, Typical Installation: Single Line Parallel System** and **Typical Installation: Series Progressive System** diagrams starting on page 9.

The unit must be securely mounted and grounded before operation.

Priming the System



1. After the tank (K) is completely filled, remove the high pressure lubricant supply line (D) from the outlet.
2. Connect power to the pump (B).
3. Start the pump (B) and run until all of the air has been expelled and fluid flow is continuous (FIG. 19).

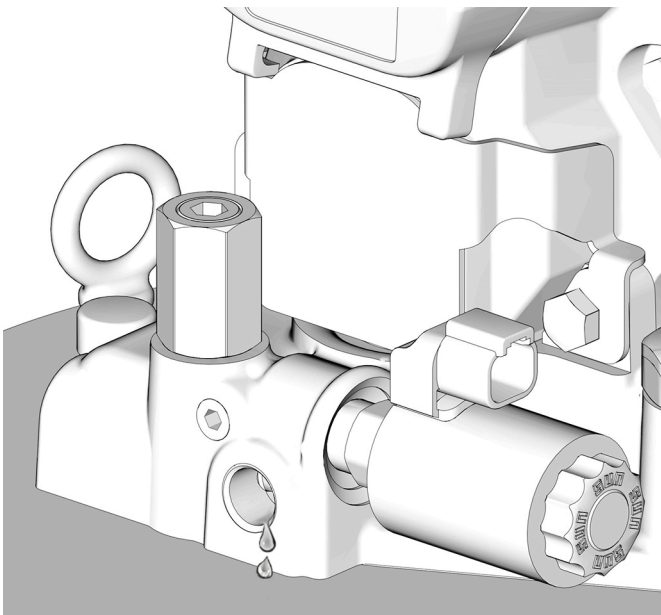

FIG. 19

4. Reconnect the high pressure lubricant supply line (D) to the outlet.

Pump Operation Overview

Single Line Parallel System

1. At the start of the cycle, the lubrication controller (F) initiates a signal that closes the vent valve (L) and starts the pump (B).
2. The pump (B) builds pressure in the supply lines (D) until all the injectors (E) actuate. Then the pressure switch (T) sends a signal to the lubrication controller (F) to end the cycle.
3. The lubrication controller (F) terminates the signal to the pump (B) and power to the vent valve (L).
4. The vent valve (L) opens.
5. Pressure is relieved in the supply lines (D), back into the tank (K), and resets all of the injectors (E).

Series Progressive System

1. At the start of the cycle, the lubrication controller (F) initiates a signal to start the pump (B).
2. The pump (B) supplies lubricant and pressure to the metering devices (AD). When the metering devices are active, they carry lubricant to the lube points.
3. Continuous lubrication is provided during pump operation.
4. To control lubrication based upon number of cycles, a cycle switch can be added to the metering devices.

Shutdown

For normal shut down, disconnect power to the lubricator controller (F) and to the pump.

Level Monitoring

Low Level Switch

The low level switch (S) (FIG. 20) indicates a fault when the follower plate (Y) reaches the factory set distance from the bottom of the tank. The fault activates when the remaining grease level is approximately 10 percent.

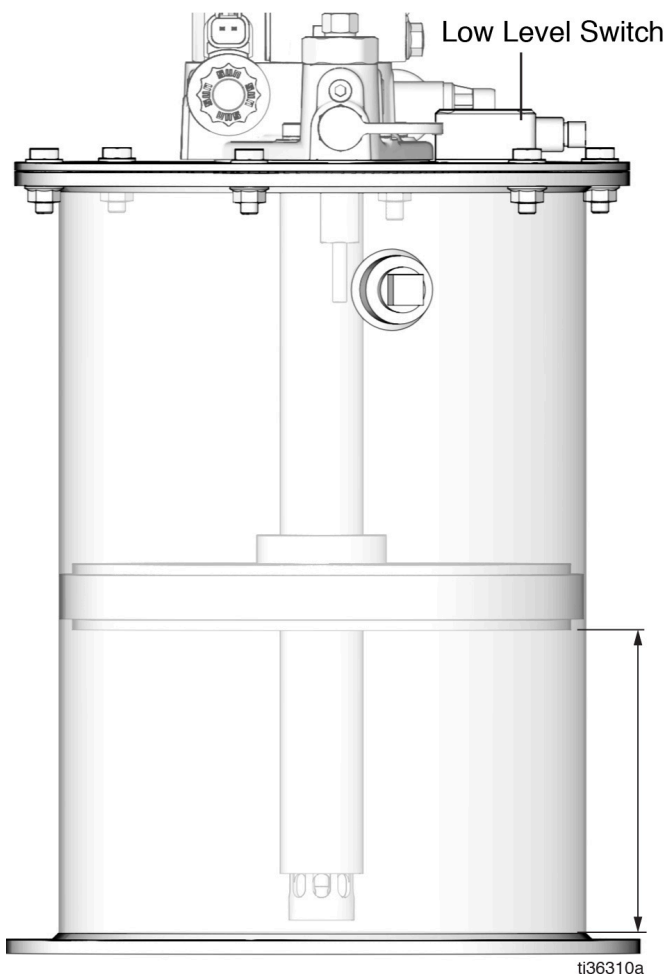

FIG. 20

NOTICE

The pump (B) should not be run without grease because air will be introduced into the system and could cause damage.

Output type:	1 switching output, PNP NO
Operating voltage:	10 - 30 VDC
Current:	200mA
Connection type:	M12x1, 4-pin

Connector on Housing	Pin-out												
	<table border="1"> <tr> <td>1</td> <td>Voltage +</td> <td>Brown</td> </tr> <tr> <td>2</td> <td>Teach Input</td> <td>White</td> </tr> <tr> <td>4</td> <td>Signal Output</td> <td>Black</td> </tr> <tr> <td>3</td> <td>Voltage -</td> <td>Blue</td> </tr> </table>	1	Voltage +	Brown	2	Teach Input	White	4	Signal Output	Black	3	Voltage -	Blue
1	Voltage +	Brown											
2	Teach Input	White											
4	Signal Output	Black											
3	Voltage -	Blue											

Example Wiring Diagram														
	<table border="1"> <tr> <td>1</td> <td>Voltage +</td> <td>Brown</td> </tr> <tr> <td>2</td> <td>Teach Input</td> <td>White</td> </tr> <tr> <td>4</td> <td>Signal Output</td> <td>Black</td> </tr> <tr> <td>3</td> <td>Voltage -</td> <td>Blue</td> </tr> </table>	1	Voltage +	Brown	2	Teach Input	White	4	Signal Output	Black	3	Voltage -	Blue	
1	Voltage +	Brown												
2	Teach Input	White												
4	Signal Output	Black												
3	Voltage -	Blue												

ti36292a

FIG. 21

Level Transducer

The level transducer (S) (FIG. 22) is used for continuous level monitoring. It indicates a fault when the follower plate (Y) reaches the factory set distance from the bottom of the tank. The fault activates when the remaining grease level is approximately 10 percent.

NOTICE
The pump (B) should not be run without grease, or air will be introduced into the system and could cause damage.

Output type:	1 analog output 0 - 10V
Operating voltage:	10 - 30 VDC
Current:	200mA
Connection type:	M12x1, 4 pin

Light Indicator

Normal:	Green
Low-Level:	Yellow
Error:	Red

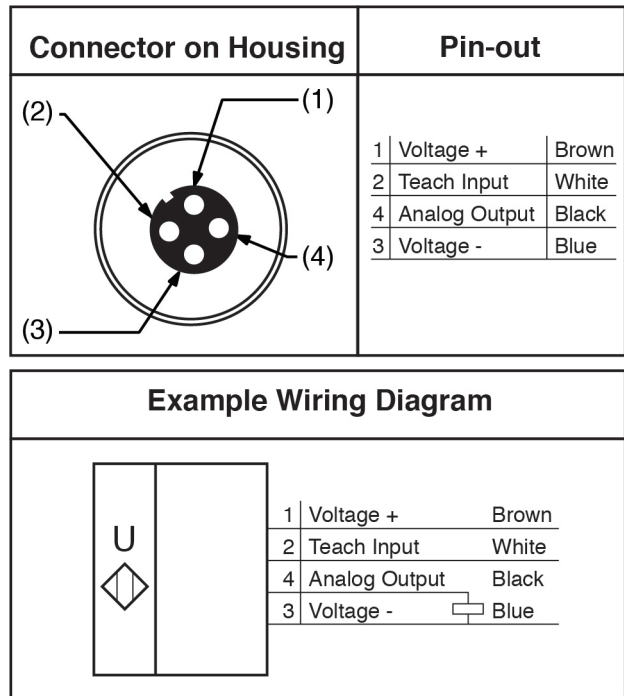

t136293a

FIG. 22

Pressure Switch

The pressure switch (T) is factory set to 3000 psi (20.7 MPa, 207 bar) (FIG. 23).

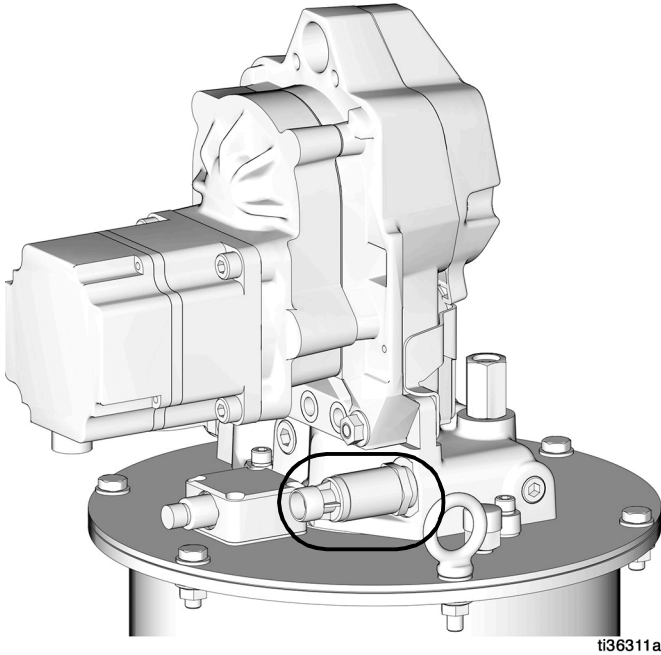

FIG. 23

When the pressure in the system reaches 3000 psi, the pressure switch (T) closes.

Output type:	1 Switching output NO
Operating voltage:	24VDC
Current:	5A
Connection type:	Packard Metri-Pack 150 Series
Preset pressure:	3000 psi

Pressure Transducer

The pressure transducer (T) is used for continuous pressure monitoring.

Output type:	Analog 1- 5V
Operating voltage:	8 - 32V
Connection type:	Packard Metri-Pack 150 Series
Pressure range:	0-5000 psi

Pressure Switch	Pin-out								
	<table border="1"> <thead> <tr> <th>PIN</th> <th>PIN Name</th> </tr> </thead> <tbody> <tr> <td>A</td> <td>Not Used</td> </tr> <tr> <td>B</td> <td>Vs</td> </tr> <tr> <td>C</td> <td>Pressure Out</td> </tr> </tbody> </table>	PIN	PIN Name	A	Not Used	B	Vs	C	Pressure Out
	PIN	PIN Name							
	A	Not Used							
	B	Vs							
C	Pressure Out								
Pressure Transducer	Pin-out								
	<table border="1"> <thead> <tr> <th>PIN</th> <th>PIN Name</th> </tr> </thead> <tbody> <tr> <td>A</td> <td>GND</td> </tr> <tr> <td>B</td> <td>Vs</td> </tr> <tr> <td>C</td> <td>Pressure Out</td> </tr> </tbody> </table>	PIN	PIN Name	A	GND	B	Vs	C	Pressure Out
	PIN	PIN Name							
	A	GND							
	B	Vs							
C	Pressure Out								

ti37033a

FIG. 24

Maintenance



Disassemble

1. Relieve pressure, following the **Pressure Relief Procedure**, page 6.
2. Disconnect the power to the system.
3. Loosen and remove the four bolts (3) holding the motor (1) to the pump, then remove the motor (1) and the o-ring (2) (FIG. 25).

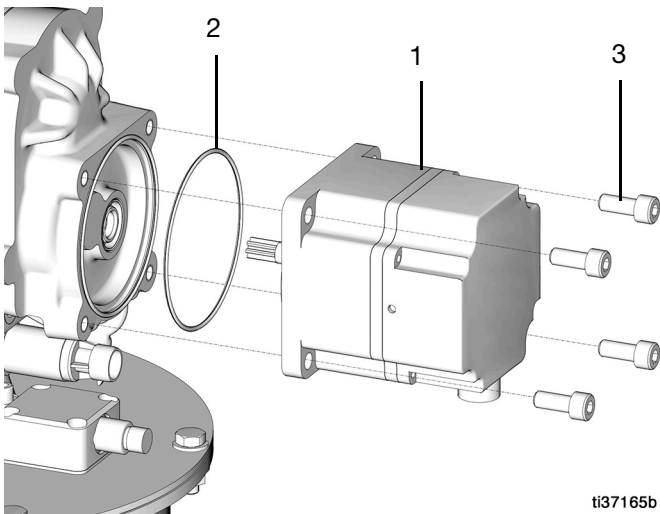

FIG. 25

ti37165b

4. Loosen and remove the four bolts (47) and four washers (48) holding the pump to the tank (41) with a 5 mm Allen wrench (FIG. 26).

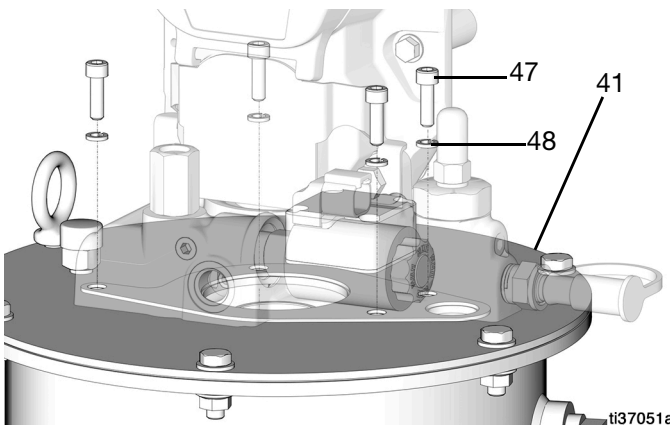

FIG. 26

ti37051e

5. Loosen and remove the bolts (55), nuts (56), washer (57), and lifting ring (53) from the cover.

NOTE: The lift ring for the 60 lb. tank is welded onto the cover and is not removable.

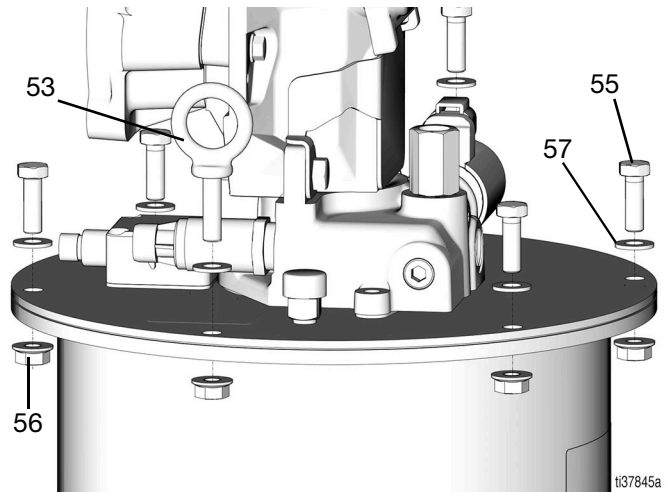

FIG. 27

ti37845a

6. Pull the pump out of the tank (41) with pump gasket (49).

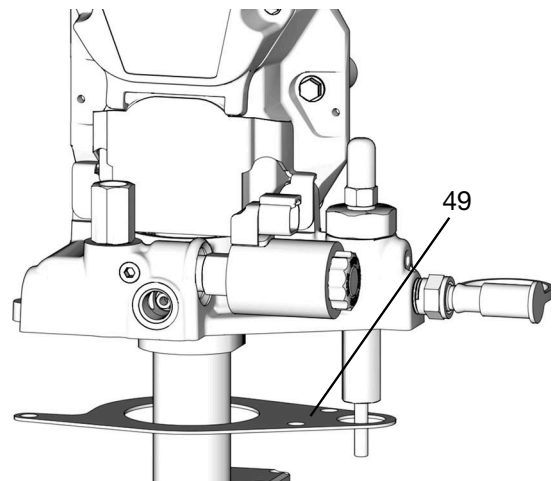

FIG. 28

- Remove the cover (54).

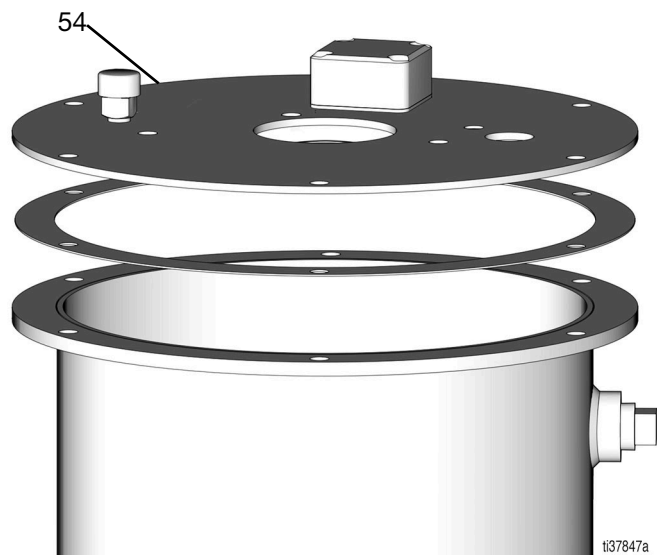

FIG. 29

- Remove the follower plate (42) and set aside.

NOTE: The follower plate for the 60 lb. tank has lift rings attached.



FIG. 30

Note: The follower plate may sink into thinner fluids.

- Remove the pressure relief valve cartridge (5) (FIG. 31).

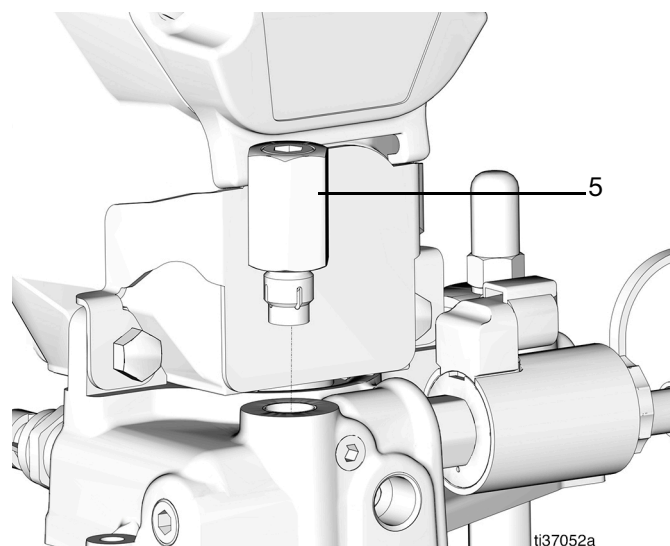

FIG. 31

- Remove the two bolts (6) and two nuts (not shown) from the protective cover (8) (FIG. 32).

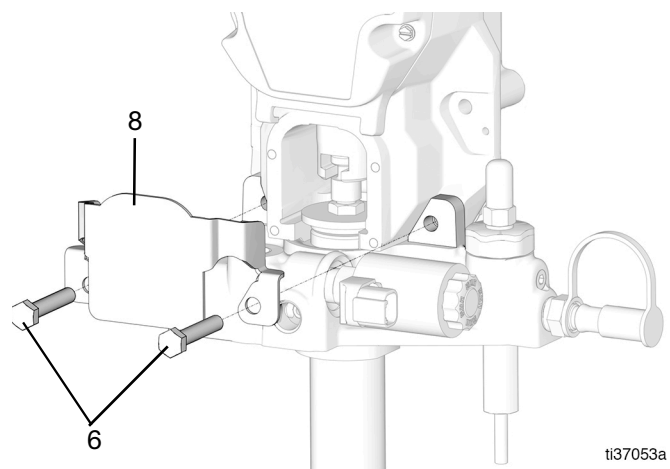

FIG. 32

- Remove the protective cover (8).
- Loosen the retaining nut (9) with a 5/8 in. open wrench (FIG. 33).

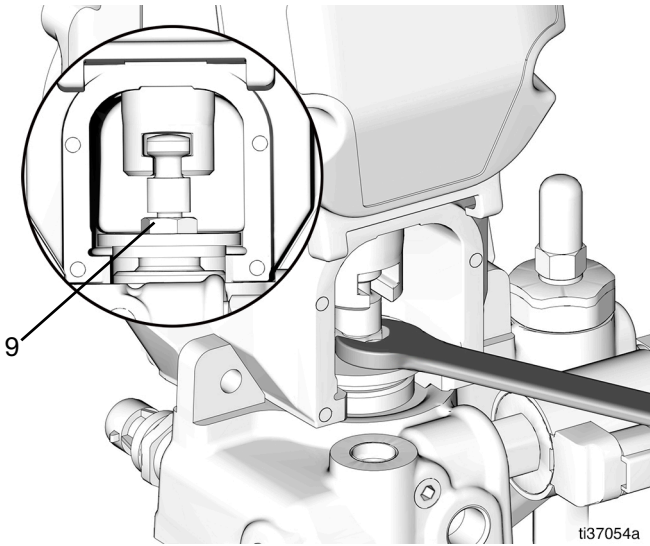

FIG. 33

13. Pull up on the lower section to separate from the gear head (4) (FIG. 34).

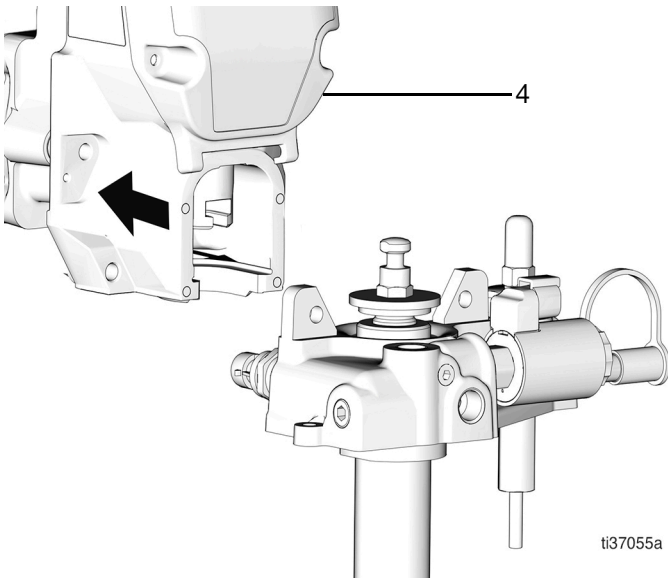

FIG. 34

14. Remove the tube-in-tube (10) with a pipe wrench. Verify the o-ring (11) is on the tube-in-tube (10) (FIG. 35).

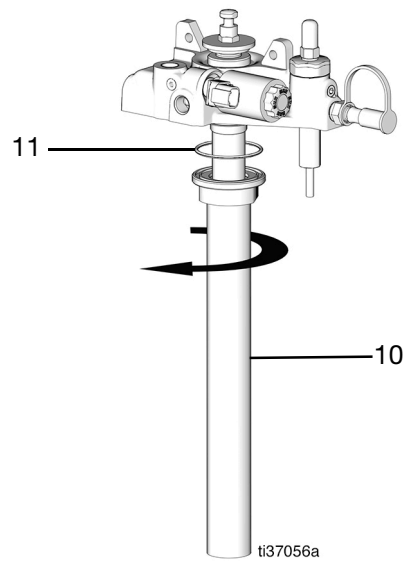

FIG. 35

15. Push on the end of the pump rod (27) to gain access to the cross-hole located at the end of the shovel rod (FIG. 36 and FIG. 37).

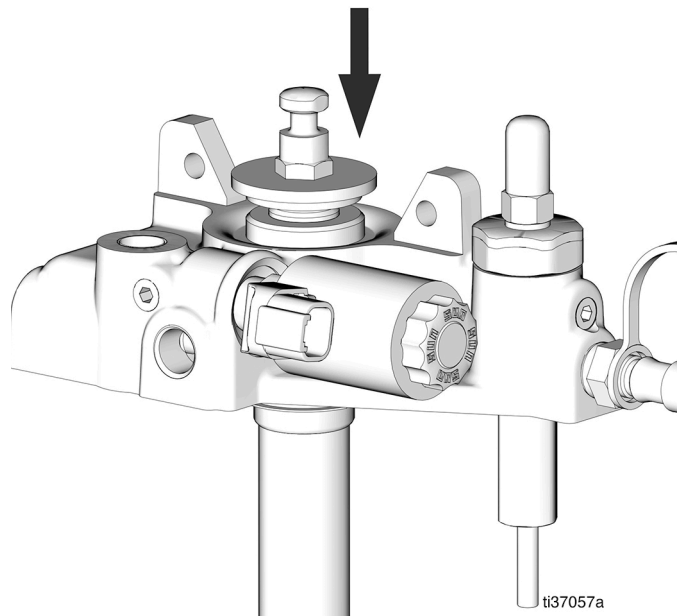
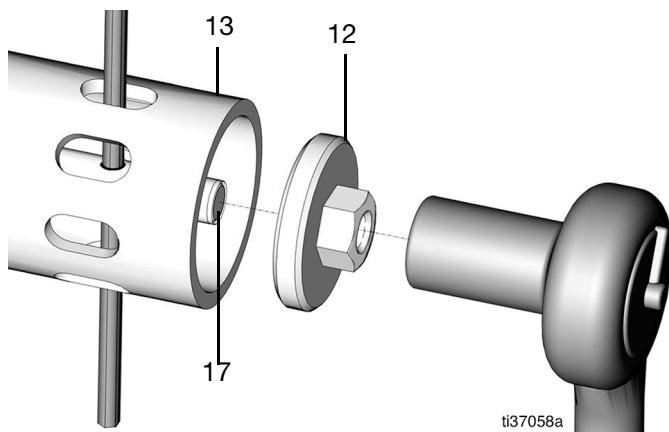
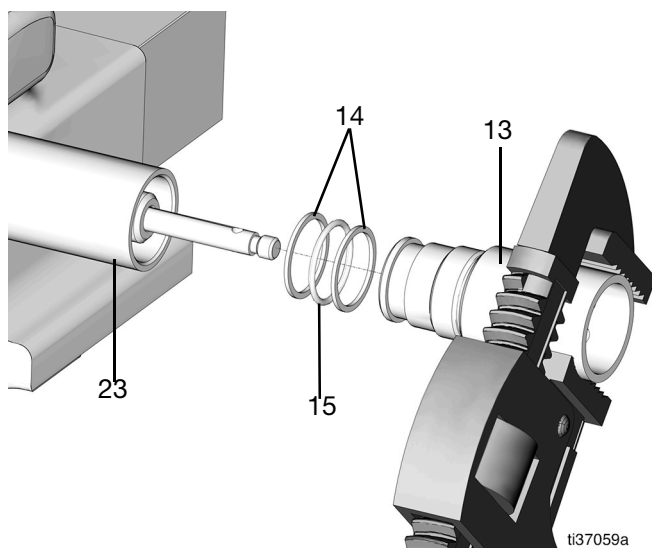

FIG. 36

16. Place an Allen wrench or similar tool through the slot of the shovel tube (13) and into the exposed cross-hole to keep the shovel rod (17) steady (FIG. 37).
17. Loosen and remove the shovel piston (12) with a 10 mm socket wrench (FIG. 37).

**FIG. 37**

18. Place the pump tube into a vise, protected by a cloth, and tighten to steady the pump lower tube (23) (FIG. 38).
19. Loosen the shovel tube (13) using a pipe wrench and remove it from the pump lower tube (23) (FIG. 38).
20. Remove the two back up rings (14) and the o-ring (15) from the shovel tube (13) (FIG. 38)

**FIG. 38**

21. Loosen and remove the pump lower tube (23) with a pipe wrench and remove the o-ring (24) from the pump lower tube (23) (FIG. 39).

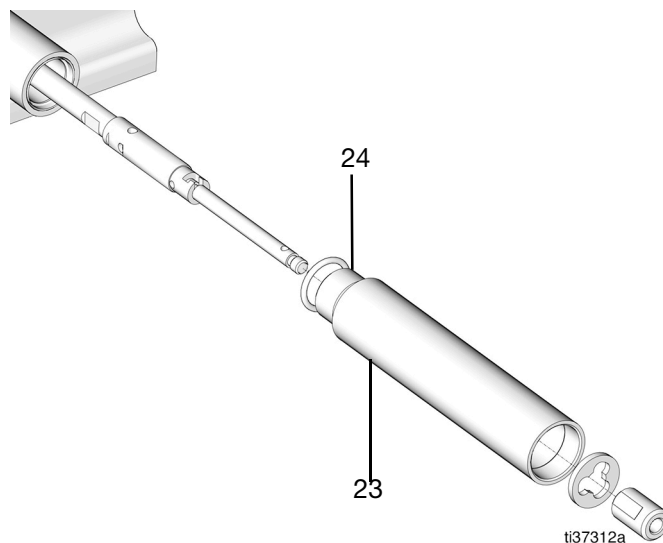
**FIG. 39**

22. Remove the shuttle valve (16) (FIG. 40).
23. Remove the spacer (18) (FIG. 40).

15

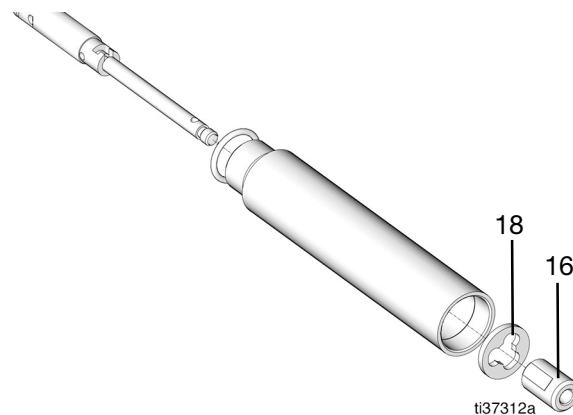
**FIG. 40**

- 24. Remove the piston bushing (19) (FIG. 41).
- 25. Remove the two (2) backup rings (20) and the o-ring (21) from the piston bushing (19) (FIG. 41).

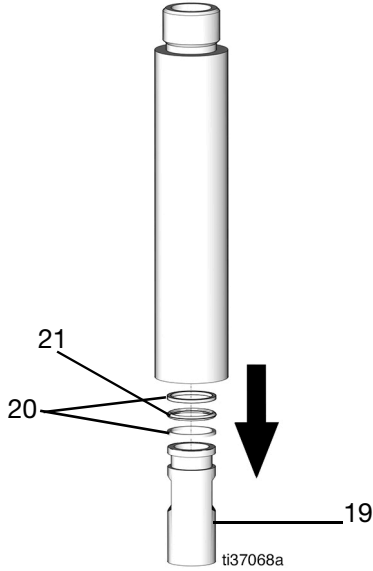

FIG. 41

- 27. Remove the pump piston (25) from the pump rod (27).

Note: Remove the ball (22) from the pump piston (25) (FIG. 43 and FIG. 44).

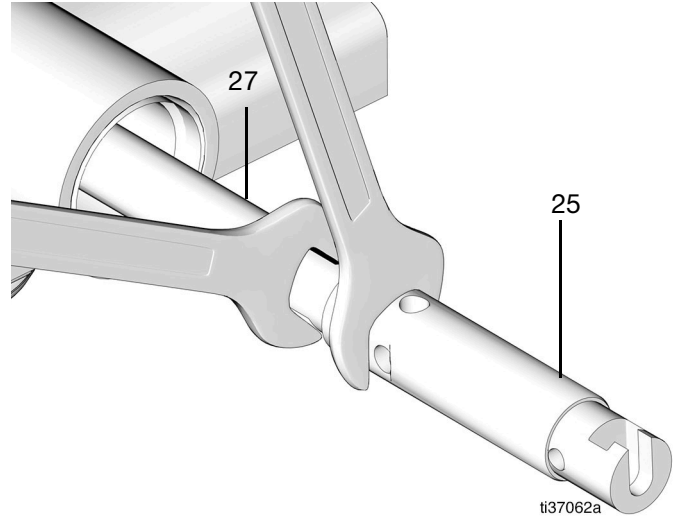

FIG. 43

- 26. Remove the shovel rod (17) from the pump piston (25) (FIG. 42).

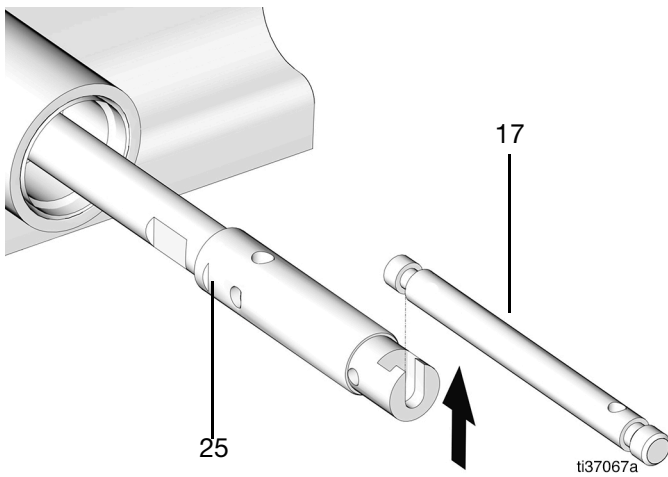

FIG. 42

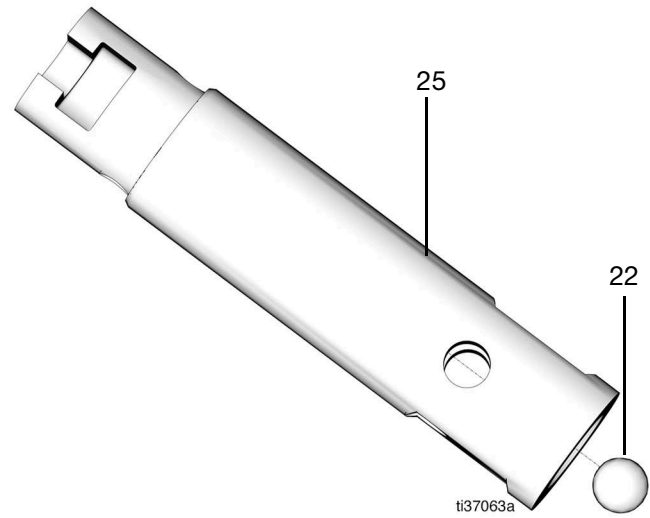

FIG. 44

28. Loosen and remove the extension tube (26) from the top housing. Remove two backup rings (14) and the o-ring (15) (FIG. 45).

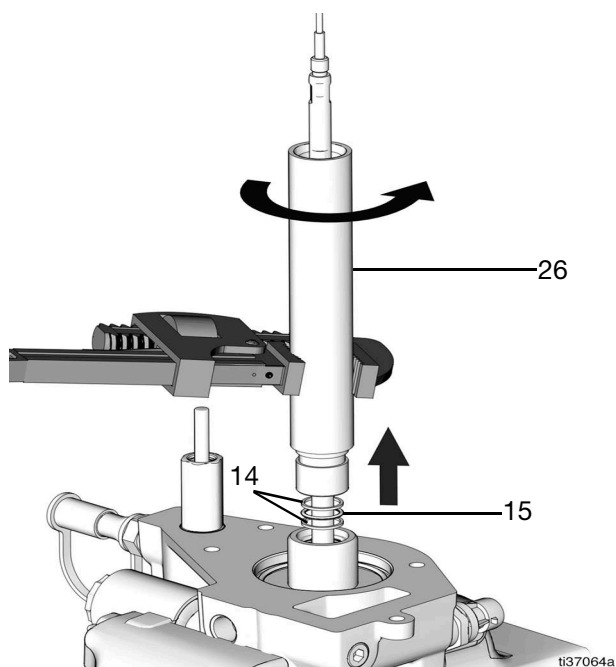

FIG. 45

29. Pull out the pump rod (FIG. 46).

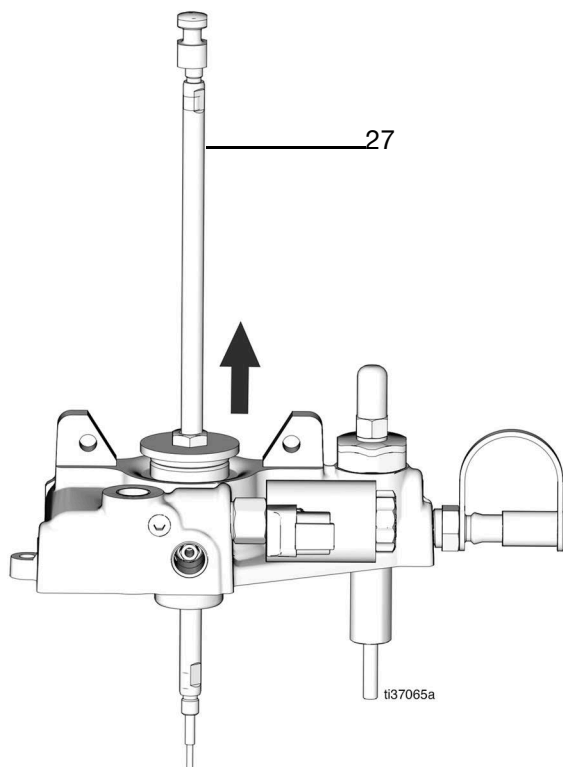

FIG. 46

30. Remove the retaining nut (9) located on the upper housing (FIG. 47).

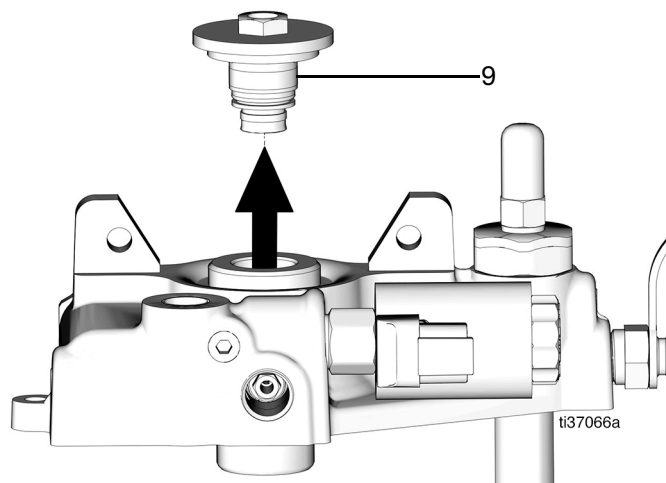

FIG. 47

31. Remove the outer o-ring (28) from the retaining nut (FIG. 48).
 32. Remove the throat screw (29) to get to the inner o-ring (30) (FIG. 48).
 33. Remove the bronze washer (31) from the pump housing (FIG. 48).
 34. Remove the throat seal (32) (u-cup) (FIG. 48).

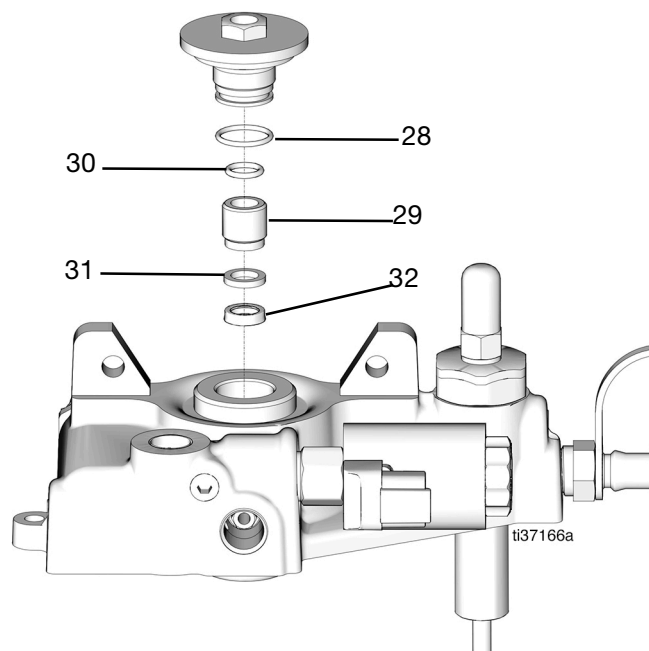

FIG. 48

35. Remove the check valve and o-ring (37) (FIG. 49).

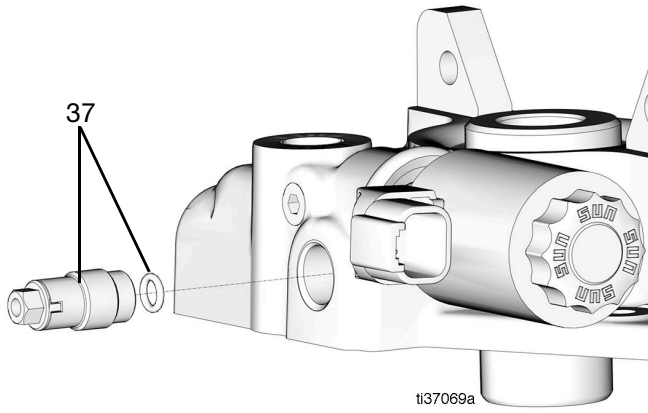

FIG. 49

Reassemble

1. Place throat seal (32) (u-cup) into the pump housing, lips downward (FIG. 50).
2. Place the bronze washer (31) on top of the throat seal (32) (u-cup) (FIG. 50).

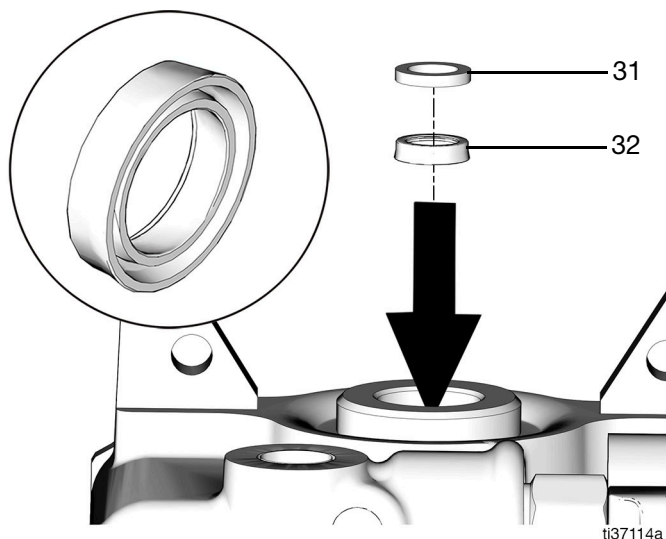

FIG. 50

3. Replace the inner o-ring (30) from the retaining nut (9) with a new o-ring and grease lightly. (FIG. 51).
4. Replace the outer o-ring (28) from the retaining nut (9) with a new o-ring and grease lightly (FIG. 51).

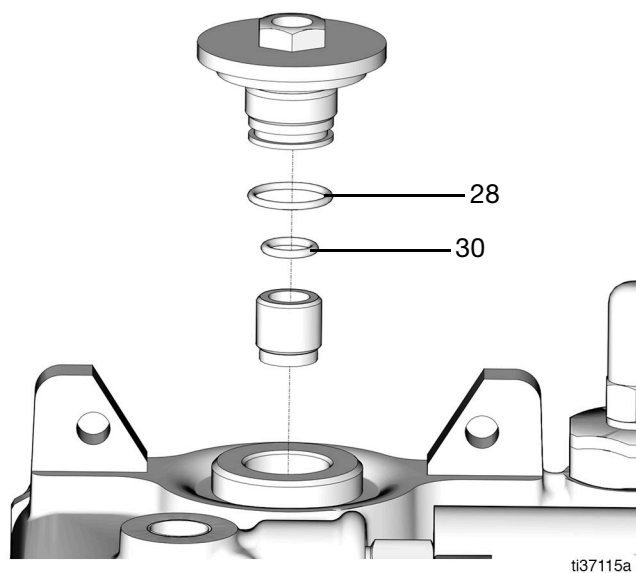

FIG. 51

5. Place the throat screw (29) into the retaining nut (9) using an Allen wrench and tighten (torque 16 ft-lb/ 21.7 N•m)

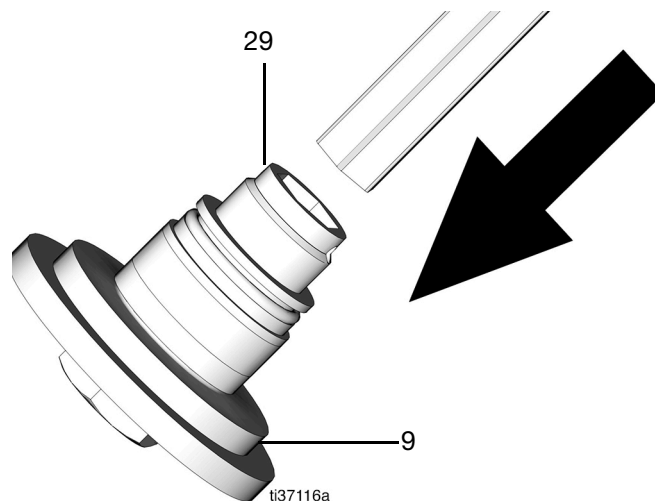

FIG. 52

6. Grease the o-ring (28) and place the retaining nut (9) into the pump housing and tighten slightly (FIG. 53).

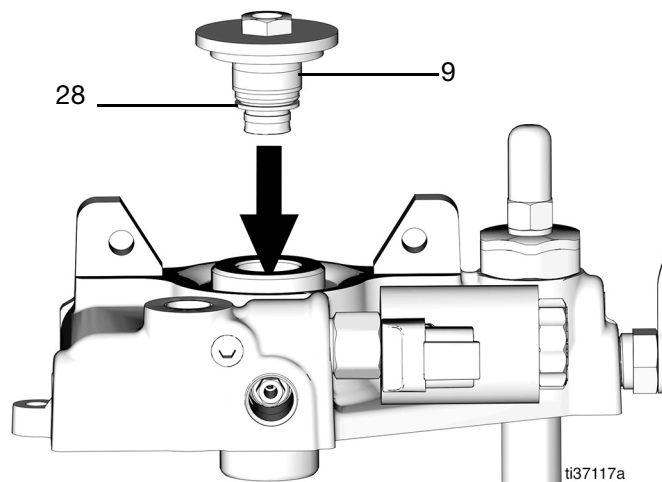

FIG. 53

- Apply a light coating of grease to the pump rod (27) and push it into the pump housing through the hole in the retaining nut (9) (FIG. 54).

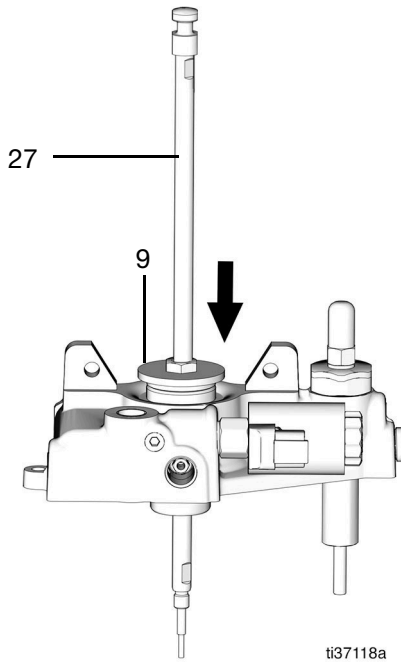

FIG. 54

- Replace the two back-up rings (14) and o-ring (15) with new back-up rings and o-ring and grease lightly (FIG. 55).
- Place the extension tube (26) over the pump rod and tighten to pump housing (torque 32 ft-lb/43.4 N•m) (FIG. 55). Apply medium strength thread locking compound.

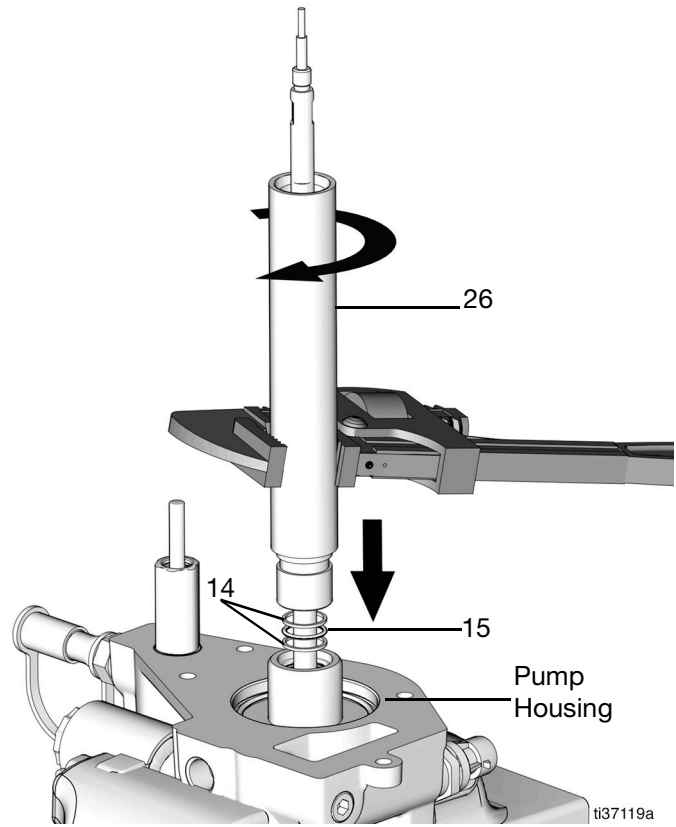

FIG. 55

- Place the ball (22) back into the pump piston (25) (FIG. 56).

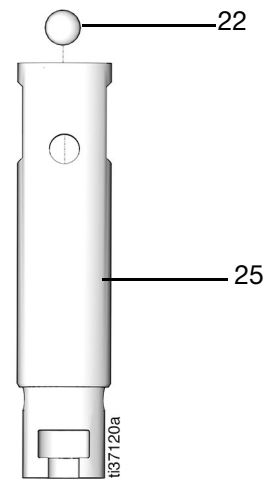

FIG. 56

- Apply medium strength thread locking compound on the threads of the pump rod (27).

12. Place the pump piston (25) on the end of the pump rod (27) and tighten using wrenches (torque 10 ft-lb/13.6 N•m) (FIG. 57 and FIG. 58).

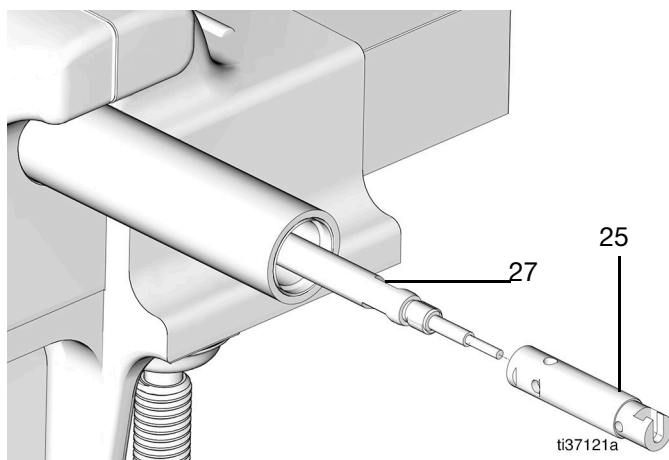

FIG. 57

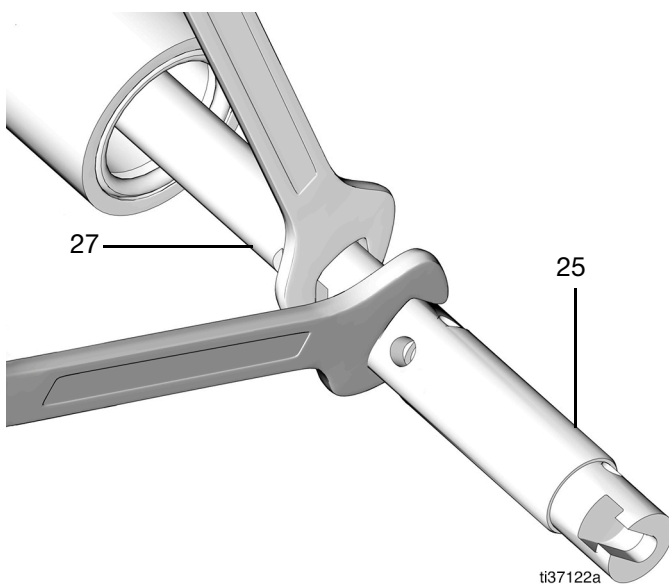

FIG. 58

13. Replace the two back-up rings (20) and o-ring (21) with new back-up rings and o-ring and grease lightly (FIG. 59).

14. Place the piston bushing (19) into the pump lower tube (23) until seated (FIG. 59).

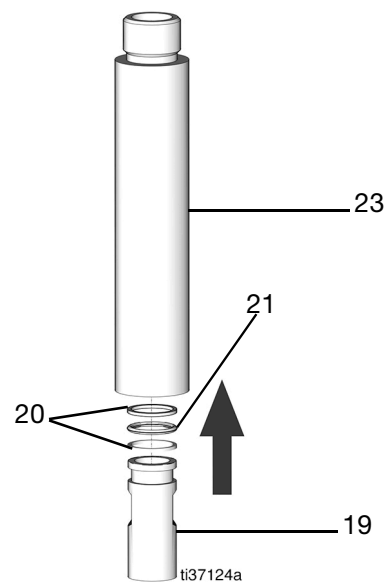

FIG. 59

15. Place the shovel rod (17) into the pump piston (25) groove (FIG. 60).

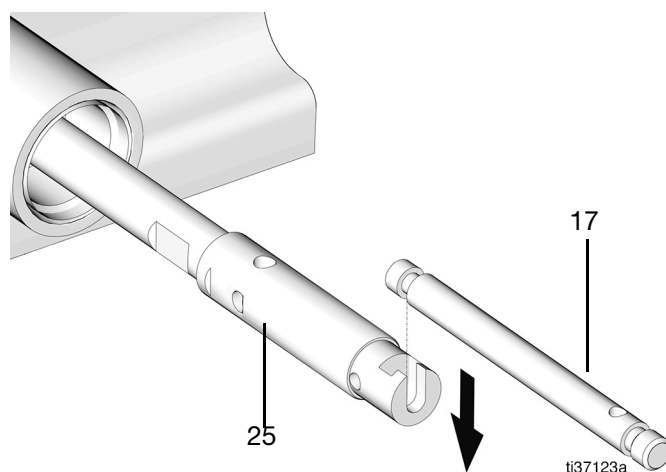

FIG. 60

16. Replace and lightly grease the o-ring (24) on the lower pump tube (23) (FIG. 61).
17. Slide the pump lower tube (23) over the pump rod (27) and connect to the extension tube (26) (torque 32 ft-lb/43.4 N•m) (FIG. 61).

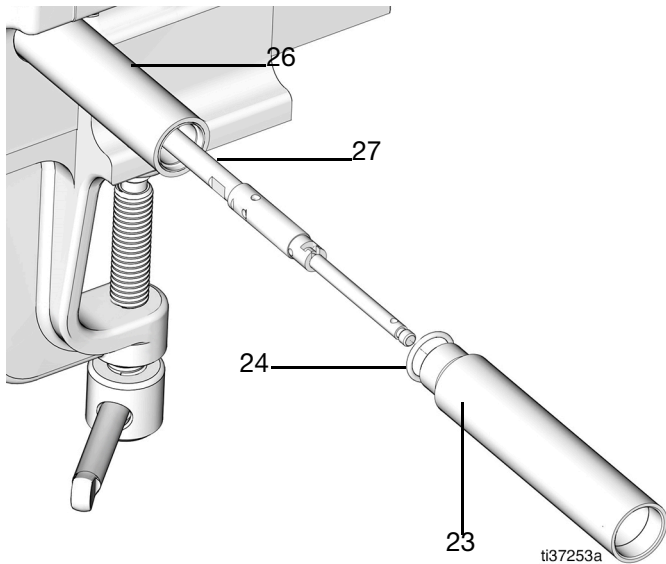

FIG. 61

18. Place the spacer (18) into the pump lower tube (23) until seated (FIG. 62).
19. Attach the shuttle valve (16) to the shovel rod (17), with the notch upward (FIG. 62).

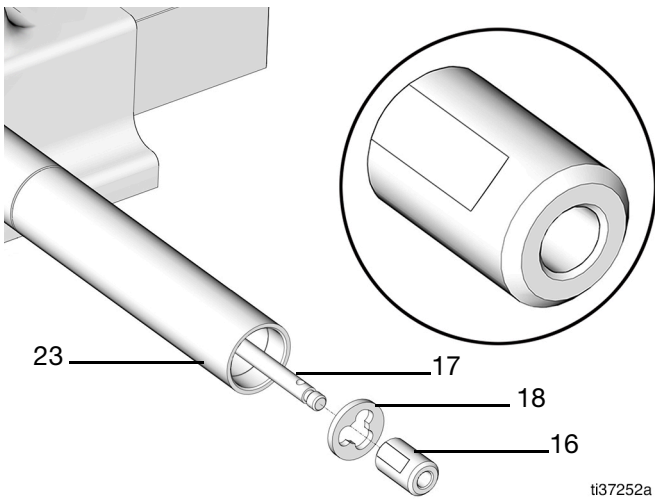

FIG. 62

20. Replace the two shovel tube (13) back-up rings (14) and the o-ring (15) and grease lightly (FIG. 63).
21. Place the shovel tube (13) into the pump lower tube (23) and tighten (torque 32 ft-lb/43.4 N•m) (FIG. 63).

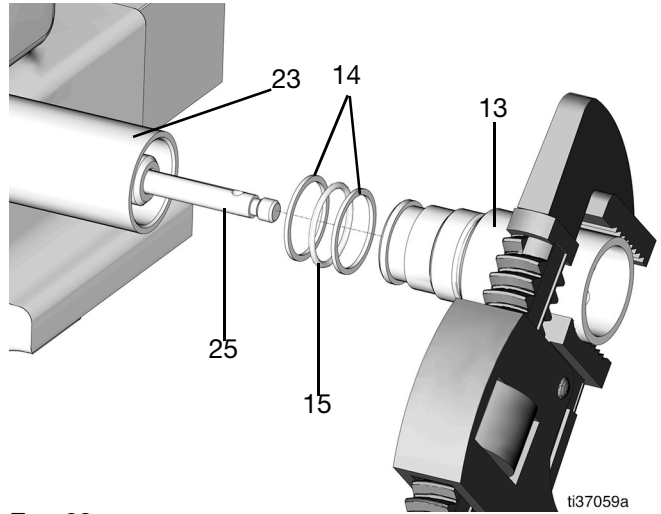

FIG. 63

22. Push pump rod (27) down to move the shovel rod (17) down to access the cross-hole (FIG. 64).
23. Place an Allen wrench or similar tool through the slot of the shovel tube (13) and into the exposed cross-hole to keep the shovel rod (17) steady (FIG. 64).
24. Tighten the shovel piston (12) with a 10 mm socket wrench (torque 3-4 ft-lb/4.1-5.4 N•m) (FIG. 64).

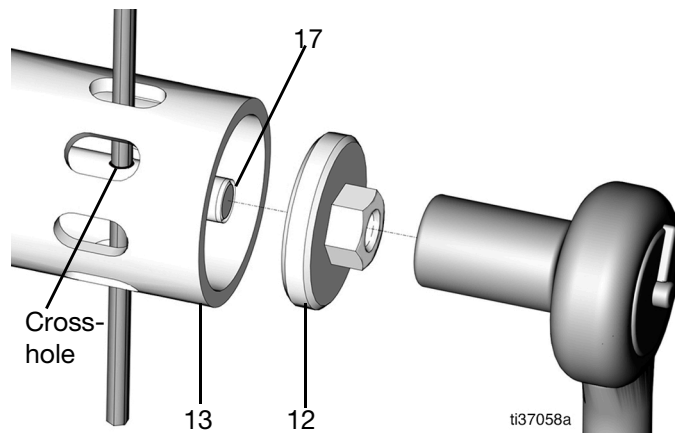

FIG. 64

25. Replace the o-ring (11) and grease lightly (FIG. 65).
26. Slide the tube-in-tube (10) over the assembly and up to the pump housing. Tighten the flange (torque 40 ft-lb/54.2 N•m) (FIG. 65 and FIG. 66).

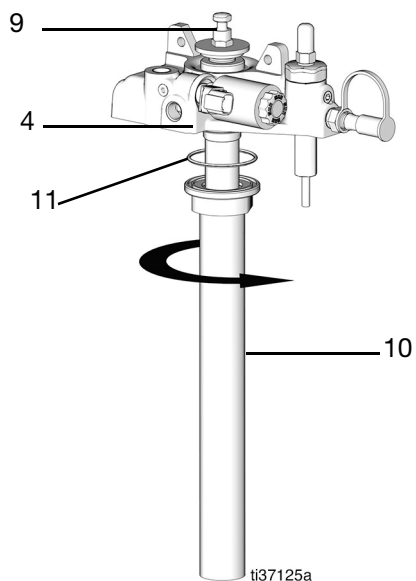

FIG. 65

27. Fit the pump assembly into the gear head (4). The retaining nut (9) can be loosened to increase the gap. Line up the pump rod (27) with the cut out and slide into place (FIG. 67).

Note: Leave the retaining nut loose (9).

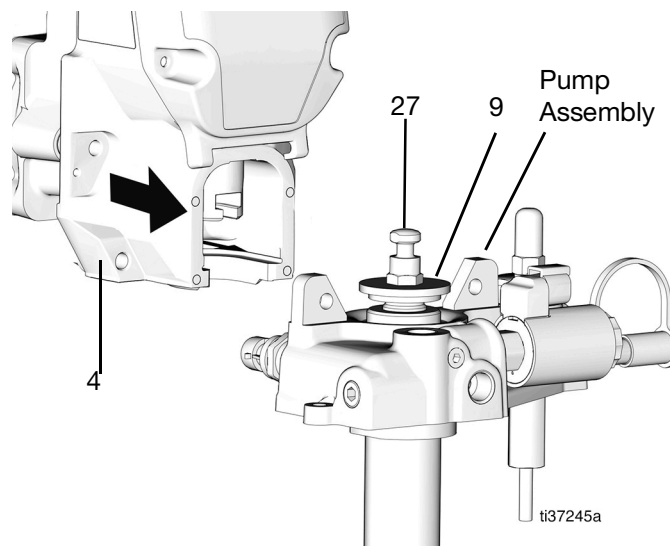

FIG. 67

28. Place two bolts (6) into the pump assembly to hold the gear head and pump assembly in place and tighten slightly the two nuts (7) (FIG. 68).

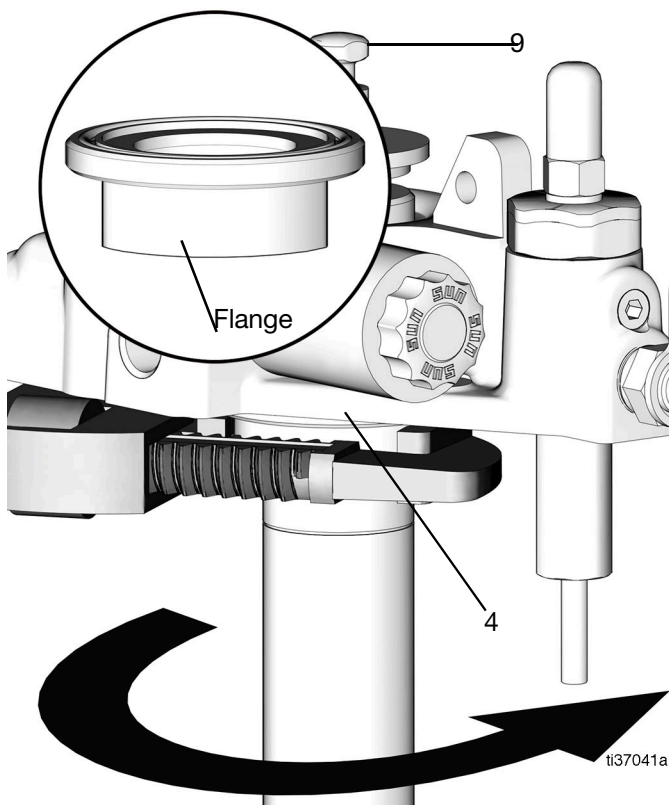

FIG. 66

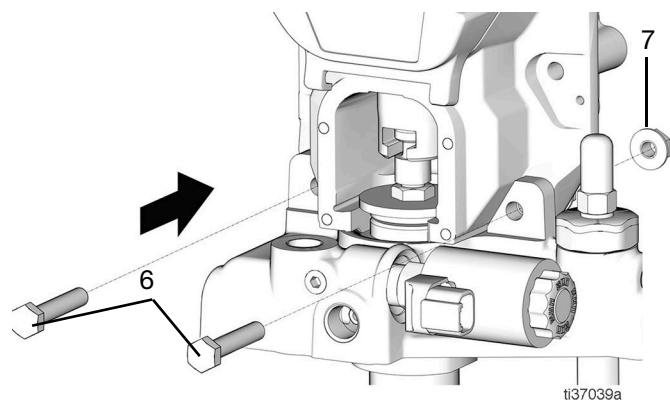

FIG. 68

29. Tighten the retaining nut (9) with a wrench (torque 30 ft-lb/40.1 N•m) to secure (FIG. 69).

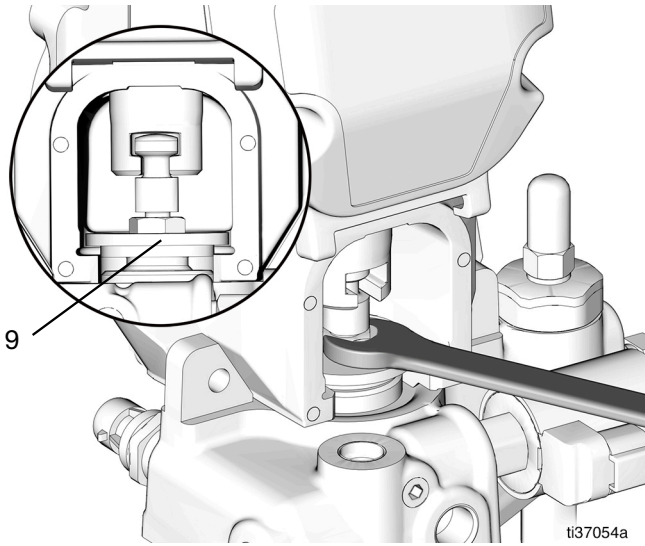

FIG. 69

31. Place the protective cover (8) in place and secure with bolts (6) and nuts (7) (not shown) (FIG. 71).

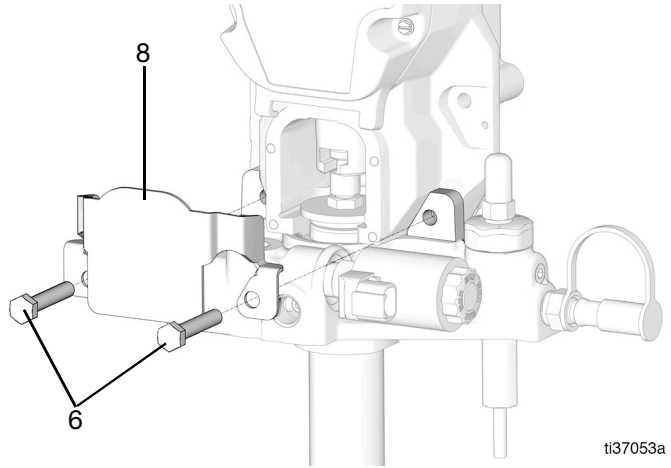

FIG. 71

30. Remove the two bolts (6) and two nuts (7) (FIG. 70).

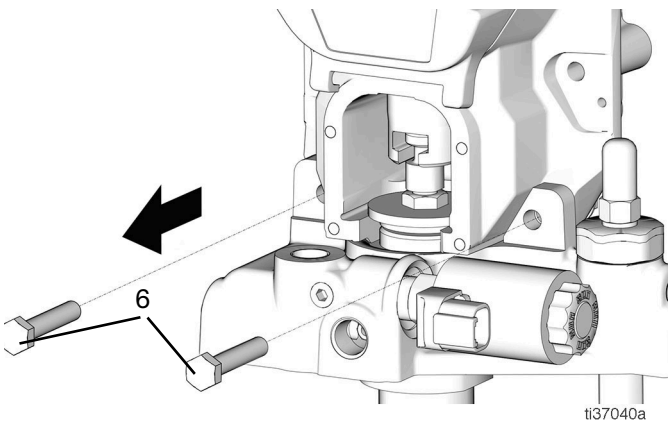

FIG. 70

32. Place the o-ring (2) and attach the motor (1) to the pump using the four bolts (3) (torque 11 ft-lb/14.9 N•m) (FIG. 72).

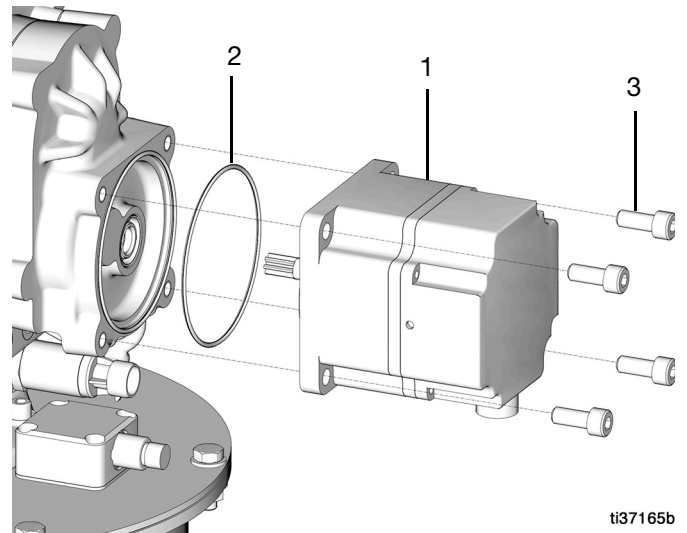

FIG. 72

33. Place the o-ring onto the check valve, and then place into the pump outlet and tighten (torque 16 ft-lb/21.7 N•m) (FIG. 73).

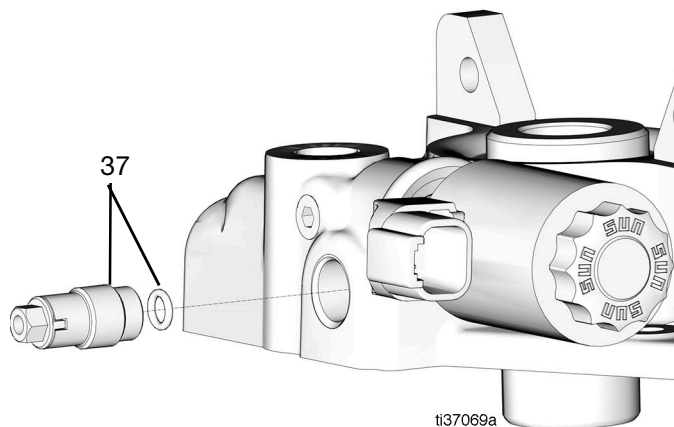

FIG. 73

34. Place the pressure relief valve cartridge (5) and tighten (torque 8 ft-lb/10.8 N•m) (FIG. 74).

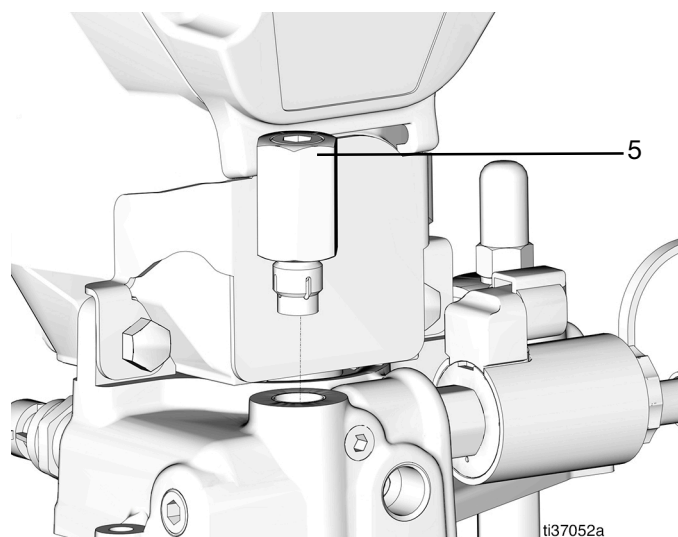
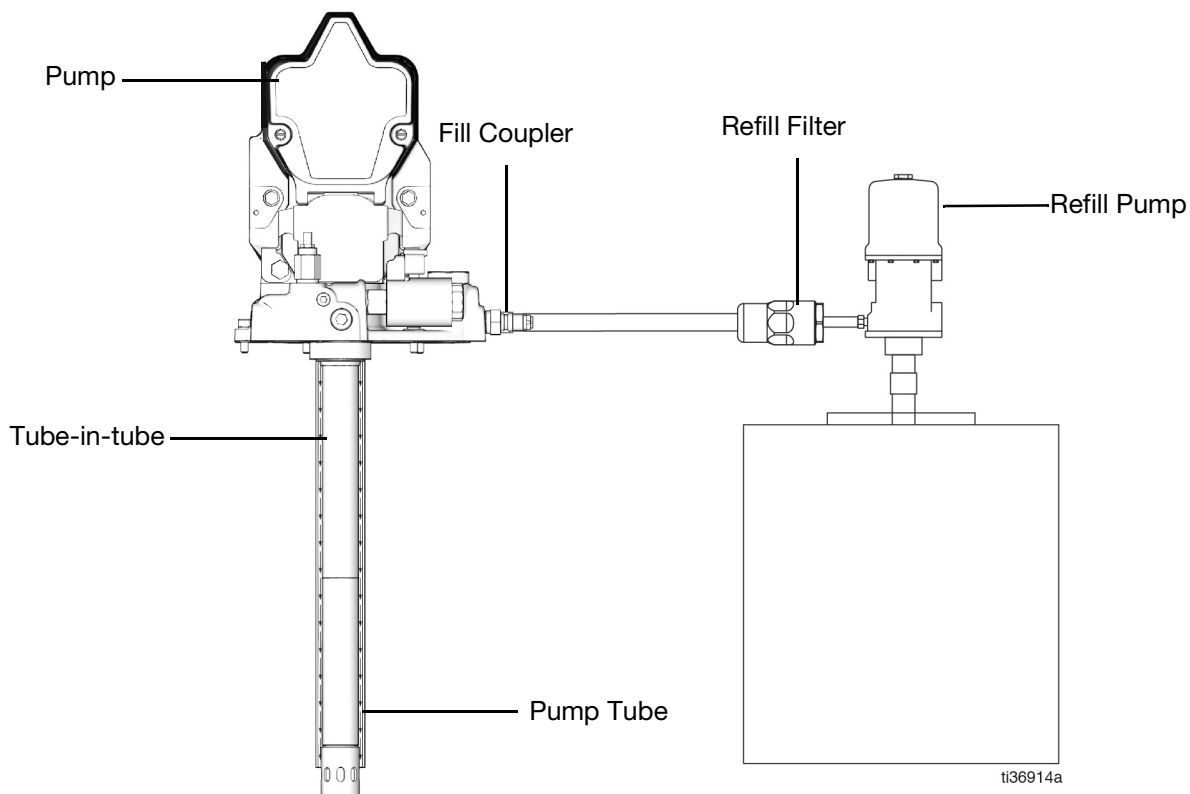

FIG. 74

Note: There is air located between the pump tube and the tube-in-tube. Remove this air by filling it with grease to prime the pump. If this is not done, the pump may lose priming during operation.



35. Connect the refill pump to the fill coupler (FIG. 75).

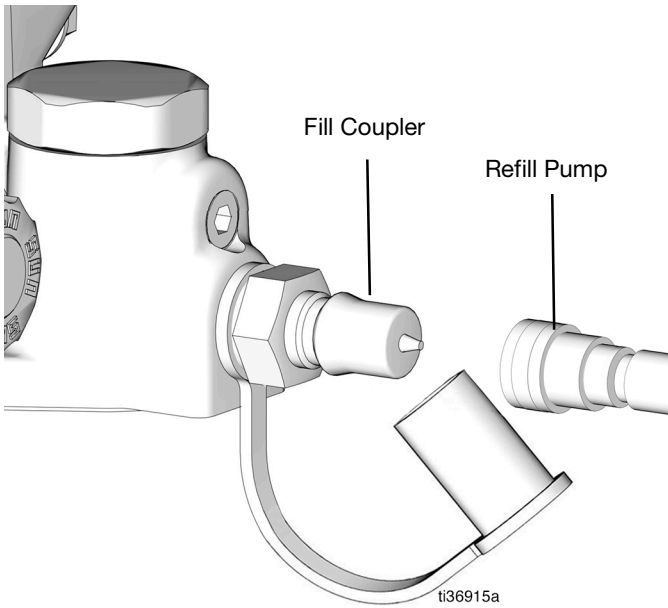

FIG. 75

36. Run the refill pump until grease comes out of the bottom of the tube-in-tube (FIG. 76).



FIG. 76

37. Place the follower plate (42) into the tank.

NOTE: The follower plate for the 60 lb. tank has lift rings attached.

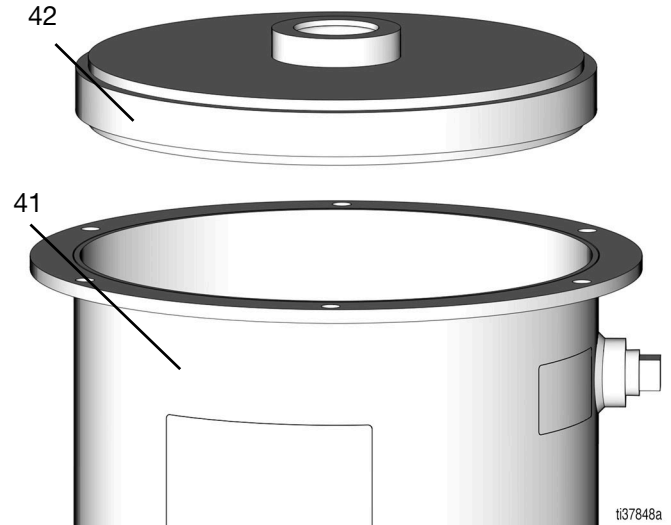

FIG. 77

Note: Best practice for thinner fluid is draining the fluid before placing the follower plate back into the tank (41).

38. Put the cover (54), with pump gasket (49), back onto the tank (41).

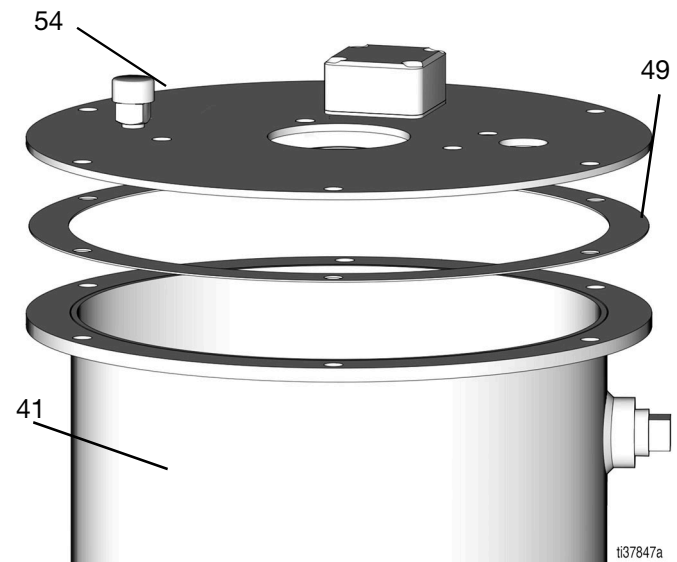

FIG. 78

39. Replace and tighten the bolts (55), nuts (56), washers (57), and lifting ring (53) back onto the cover (54).

NOTE: The lift ring for the 60 lb. tank is welded onto the cover and is not removable.

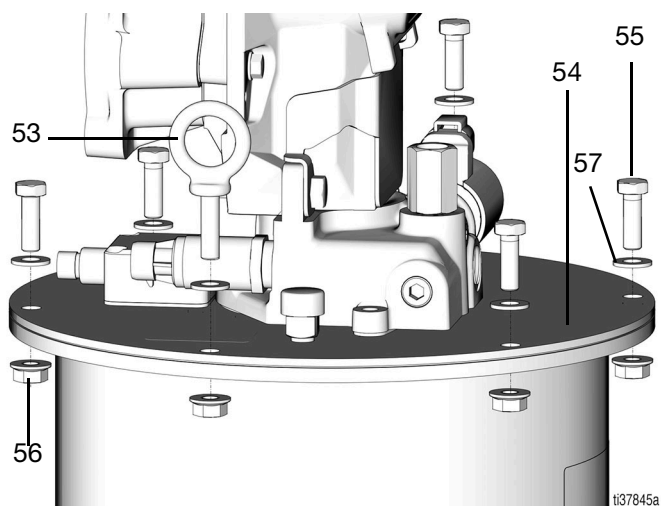

FIG. 79

40. Put the pump back into the tank (41) through the cover and the gasket (49) (FIG. 81).

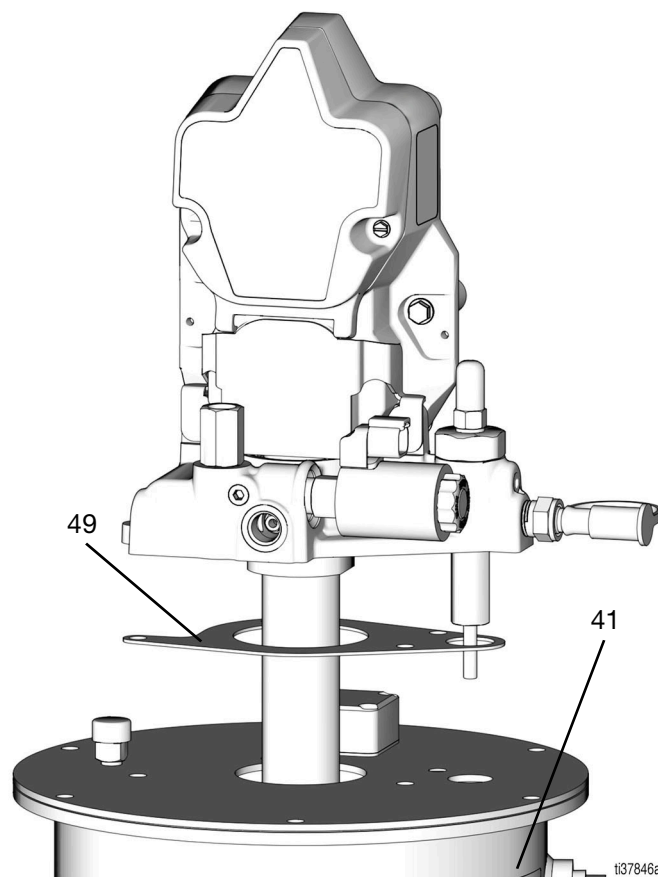

FIG. 80

41. Place the four bolts (47) and four washers (48) into place and tighten with a 5 mm Allen wrench (torque 16 ft-lb/21.7 N•m) (FIG. 81).

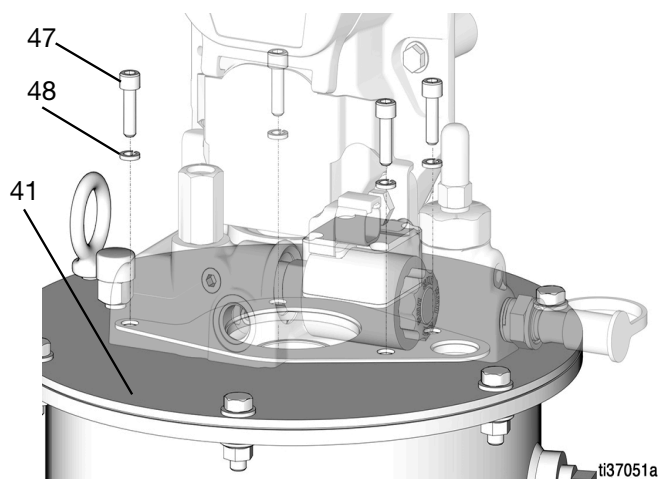
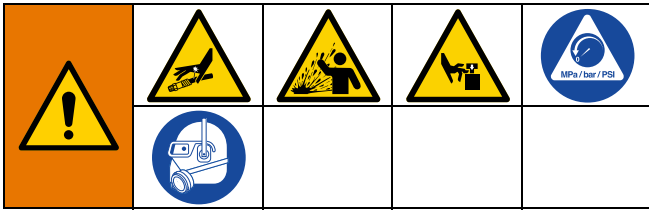

FIG. 81

42. Reconnect the power to the system.

Troubleshooting



1. Follow **Pressure Relief Procedure**, page 6, before checking or repairing the pump.
2. Check all possible problems and causes before disassembling the pump.

Problem	Cause	Solution
Pump is not powering ON. The red LED on the motor is not ON.	Wiring is incorrect Polarity is wrong Loose wire(s)	Check and verify that the wire connections are tight. Check and correct polarity.
	Fuse is: Wrong amperage Not in place or missing Faulty	Check the fuse rating and replace with new or correct amperage fuse.
	The lubrication controller is in OFF mode.	Set the lubrication controller to the correct lube cycle.
	The lubrication controller output not functional.	Check voltage at lubrication controller output.

Problem	Cause	Solution
Pump in not powering ON. The red LED on the motor is blinking.	2 blinks indicate: over current pump is jammed	Remove the pump and repair with new pump element parts.
	2 blinks indicate: over current pump is jammed The grease is too thick or the ambient temperature is too cold to pump.	Replace the grease if it is too thick or the ambient temperature is too cold to pump the grease. Replace grease with correct temperature rated grease.
	3 blinks indicate the motor is losing the signal.	Verify that the wire connections are tight. Correct polarity. Replace the motor.
	4 blinks indicate low voltage.	Check voltage and correct as needed.
	5 blinks indicate high voltage.	Check voltage and correct as needed.
	6 blinks indicate an over temperature motor windings.	High duty cycle, set to 50% duty cycle.
	6 blinks indicate an over temperature motor windings.	Remove the pump and repair with new pump element parts, if the pump is jammed,
	6 blinks indicate an over temperature motor windings.	Replace grease with correct temperature rated grease.
	7 blinks indicate over temperature on motor driver.	High duty cycle, set to 50% duty cycle.
	7 blinks indicate over temperature on motor driver.	Remove the pump and repair with new pump element parts, if the pump is jammed,
7 blinks indicate over temperature on motor driver.	Replace grease with correct temperature rated grease.	
The Pump is cycling, but there is no lubricant output from the outlet	The lubricant level in the tank is too low.	Refill the tank.

Problem	Cause	Solution
<p>The Pump is cycling, but there is no lubricant output from the outlet. The Pump lost priming/pump is cavitating.</p>	<p>Tank was not refilled through the fill port. Air in the tube-in-tube was pushed into the grease tank.</p>	<p>Connect the refill pump to the fill port and fill tank to remove any air.</p>
	<p>Airlock inside of the pump.</p>	<p>Remove the pump outlet check valve and o-ring (37). Connect the refill pump to the fill port and fill the tank to remove air. Run the Compact Dyna-Star until lubricant come out. Reassemble the outlet check valve and o-ring (37).</p>
	<p>Grease inside of the tank is not moving to the pump shovel tube.</p>	<p>Install follower plate to help distribute grease during pump operation.</p>
	<p>Follower plate is not moving and is stuck inside of the tank.</p>	<p>Inspect and replace follower plate, if necessary.</p>
	<p>Follower plate is sunk into the tank.</p>	<p>The grease viscosity is too low. Remove the follower plate.</p>
	<p>The pump element parts are worn or damaged.</p>	<p>Replace with new pump element parts.</p>
<p>Pump is cycling, there is output of fluid at the outlet, but pump pressure is not building.</p>	<p>Pump element parts are worn or damaged.</p>	<p>Replace with new pump element parts.</p>
	<p>Vent valve is not energized in the single line parallel system.</p>	<p>Check the wiring and correct.</p>
	<p>Vent valve is energized but not closing (leaky vent valve).</p>	<p>Open the inspection plug (AB), page 12, to confirm that the vent valve is not closing (leaky). Replace the vent valve.</p>
	<p>Pressure relief is leaky.</p>	<p>Open the inspection plug (AB), page 12, to confirm pressure relief is leaky. Replace pressure relief valve.</p>
<p>Pressure in the system not reduce and the injectors are not reset.</p>	<p>The vent valve is not opened to vent pressure.</p>	<p>Replace the vent valve.</p>

Parts

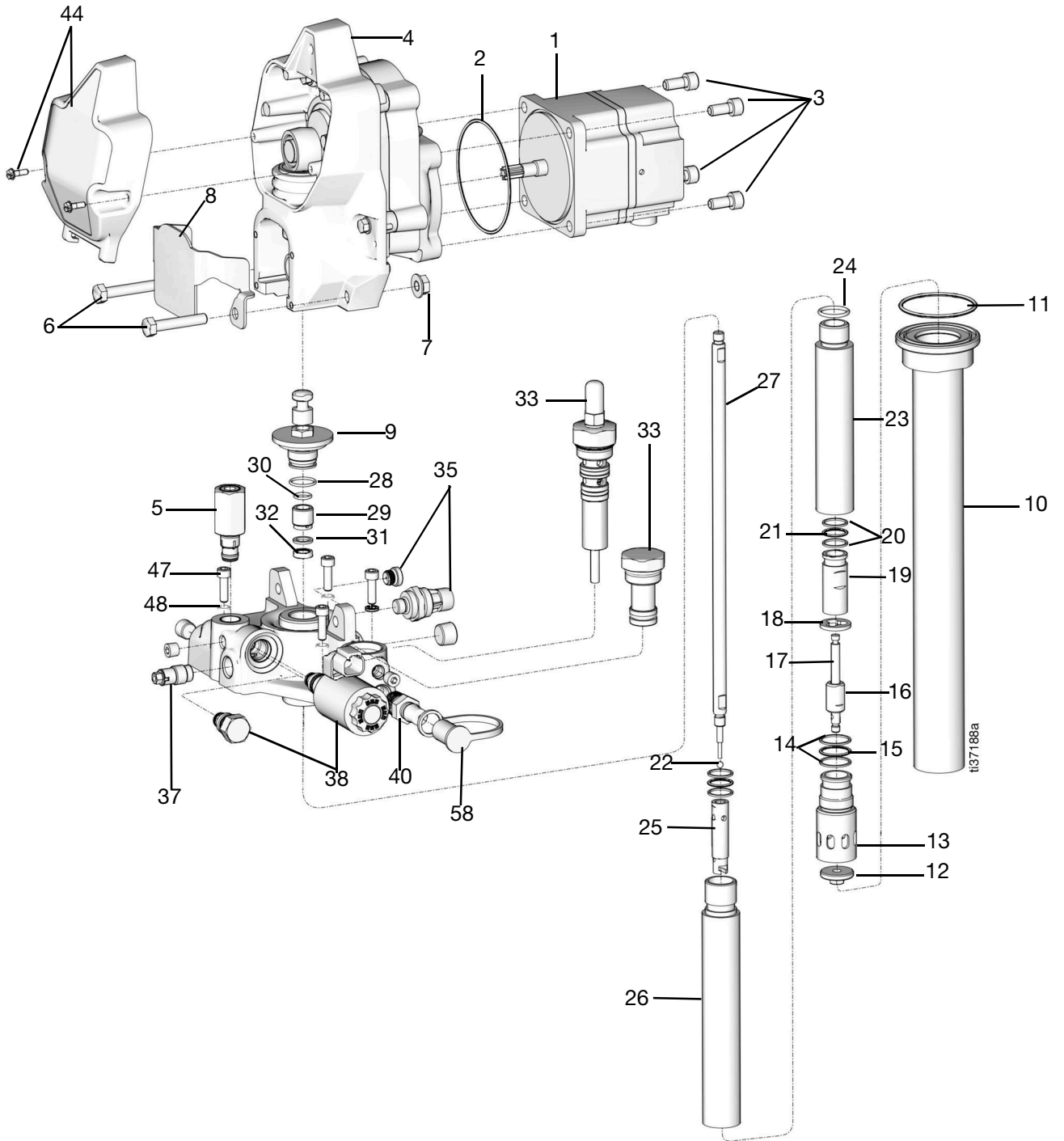

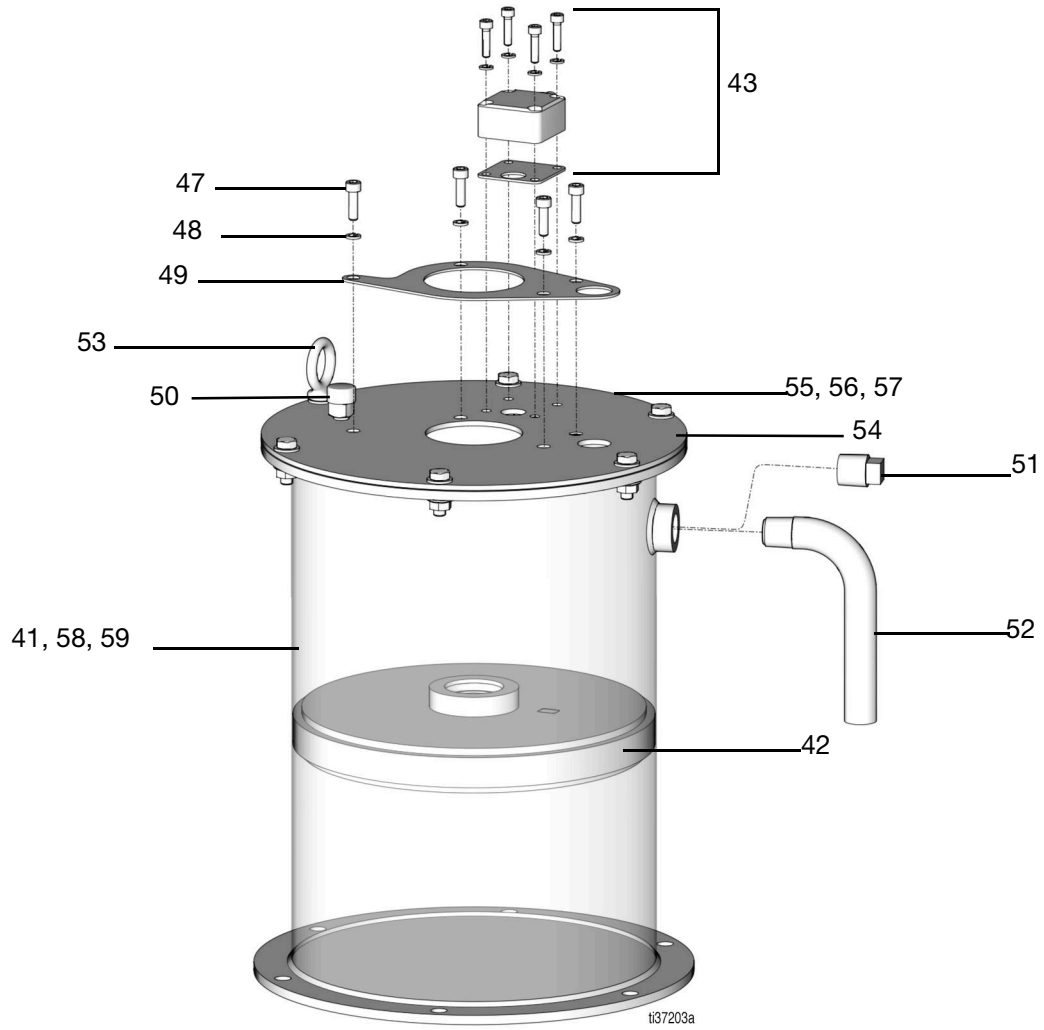

Part No./Description

Ref.	Part	Description	Qty.
1	*	Motor	1
2	*	O-ring	1
3	*	Motor bolts	4
4		Gear head	1
5	25R009	Pressure relief valve	1
6	◆	Bolt	2
7	◆	Nut	2
8	◆	protective cover	1
9		Retaining nut	1
10	★	Tube-in-tube	1
11	★	O-ring	1
12		Shovel piston	1
13		Shovel tube	1
14	❖	Back up rings	4
15	❖	O-ring	2
16	†	Shuttle valve	1
17	†	Shovel rod	1
18		Spacer	1
19	†	Piston bushing	1
20	❖	Back up rings	2
21	❖	O-rings	1
22	†	Steel ball	1
23		Pump lower tube	1
24	❖	O-ring	1
25	†	Pump piston	1
26		Pump extension tube	1
27		Pump rod	1
28	❖	O-ring	1
29		Throat screw	1
30	❖	O-ring	1
31	❖	Washer	1
32	❖	U-cup seal	1
33	25P686	Auto-fill shut off	1
33	25P685	Auto-fill shut off plug	1
35	25R333	Pressure switch	1
35	25R332	Pressure transducer	1
35	567251	Plug	
37	25P689	Check valve assembly	1
38	25P690	Vent valve (Single Line Parallel System)	1
38	25R023	Vent valve plug (Series Progressive System)	1
40+	557880	Refill adapter	1

Ref.	Part	Description	Qty.
41	25E166	Tank assembly with follower plate 12 Liter, low level switch for AFSO models	1
	25E323	Tank assembly with follower plate 12 Liter, level transducer for AFSO models	1
	25E324	Tank assembly with follower plate 20 Liter, low level switch for AFSO models	1
	25E167	Tank assembly with follower plate 20 Liter, level transducer for AFSO models	1
	26B641	Tank assembly with follower plate 60 lb., low level switch for AFSO models.	1
	26B640	Tank assembly with follower plate 60 lb., low level transducer for AFSO models.	1
58	25R124	Tank assembly 12 Liter, low level switch, no follower plate, overflow tube	1
	25R122	Tank assembly 12 Liter, level transducer, no follower plate, overflow tube	1
	25R125	Tank assembly 20 Liter, low level switch, no follower plate, overflow tube	
	25R123	Tank assembly 20 Liter, level transducer, no follower plate, overflow tube	
	26B645	Tank assembly 60 lb., low level switch, no follower plate, overflow tube.	1
	26B644	Tank assembly 60 lb., low level transducer, no follower plate, overflow tube.	
59	25R118	Tank assembly with follower plate, 12 Liter, level transducer, overflow tube	
	25R119	Tank assembly with follower plate 20 Liter, level transducer, overflow tube	
	25R120	Tank assembly with follower plate 12 Liter, low level switch, overflow tube	
	25R121	Tank assembly with follower plate 20 Liter, low level switch, overflow tube	

Parts

Ref.	Part	Description	Qty.
	26B643	Tank assembly with follower plate 60 lb., low level switch overflow tube.	1
	26B642	Tank assembly with follower plate 60 lb., low level transducer overflow tube.	1
42*	25P693	Follower plate assembly (12 L, 20 L)	1
	25U219	Follower plate assembly (60 lb.)	1
43✓	25P695	Low Level Switch Kit 12 Liter	1
	25P696	Low Level Switch Kit 20 Liter	1
	25T920	Low Level Switch Kit 60 lb.	1
43	25P694	Level Transducer Kit 12 Liter	1
	25P697	Level Transducer Kit 20 Liter	1
	25T919	Level Transducer Kit 60 lb.	
44	25P683	Front cover black with screws and label	1
45▲	130766	Warning label English (not shown)	1
46▲	130899	Warning Label French and Spanish (not shown)	1
47	✓	M6 x 20 bolts	4
48	✓	M6 Lock washers	4
49	✓	Pump gasket	1
50	✓	Breather	1
51	✘	Overflow port plug	1

Ref.	Part	Description	Qty.
52	‡	Overflow tube	1
53	✓	Eye bolt (12L and 20L only)	1
54	✓	Tank cover	1
55	✓	Bolts	5
56	✓	Nut	5
57	✓	Washer	5
58	557875	Dust cap	1

▲ Replacement safety labels, tags, and cards are available at no cost.

Related Kits

Ref	Part No.	Description
*	25P688	Motor Parts Kit
★	25P691	Tube-in-Tube 12 Liter Kit
★	25P692	Tube-in-Tube 20 Liter Kit
★	26B657	Tube-in-Tube 60 lb. Kit
◆	25P684	protective Cover Kit
†	25P945	Pump Element Kit
❖	25P946	Pump Seal Kit
✓		Also included with 41, 58, 59
✘		Also included with 41
‡		Also included with 58, 59
*		Also included with 41, 59
+	121474	Mating Coupler

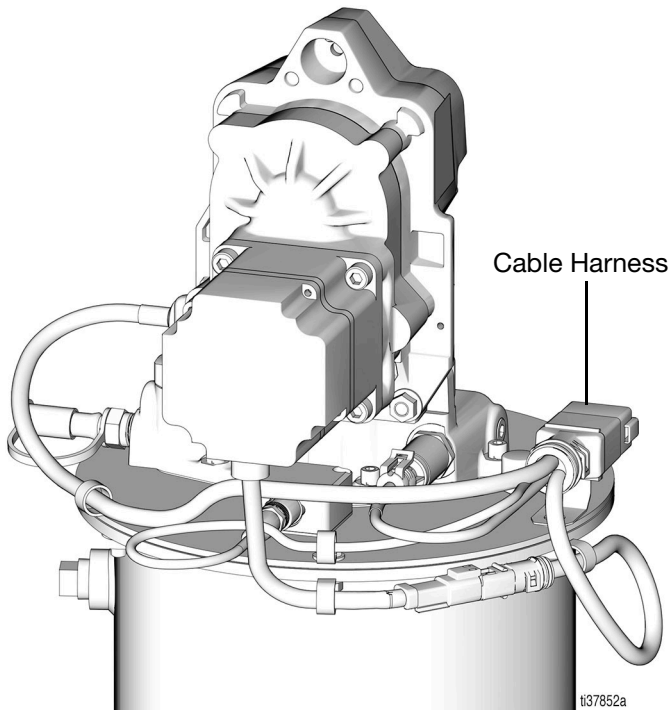
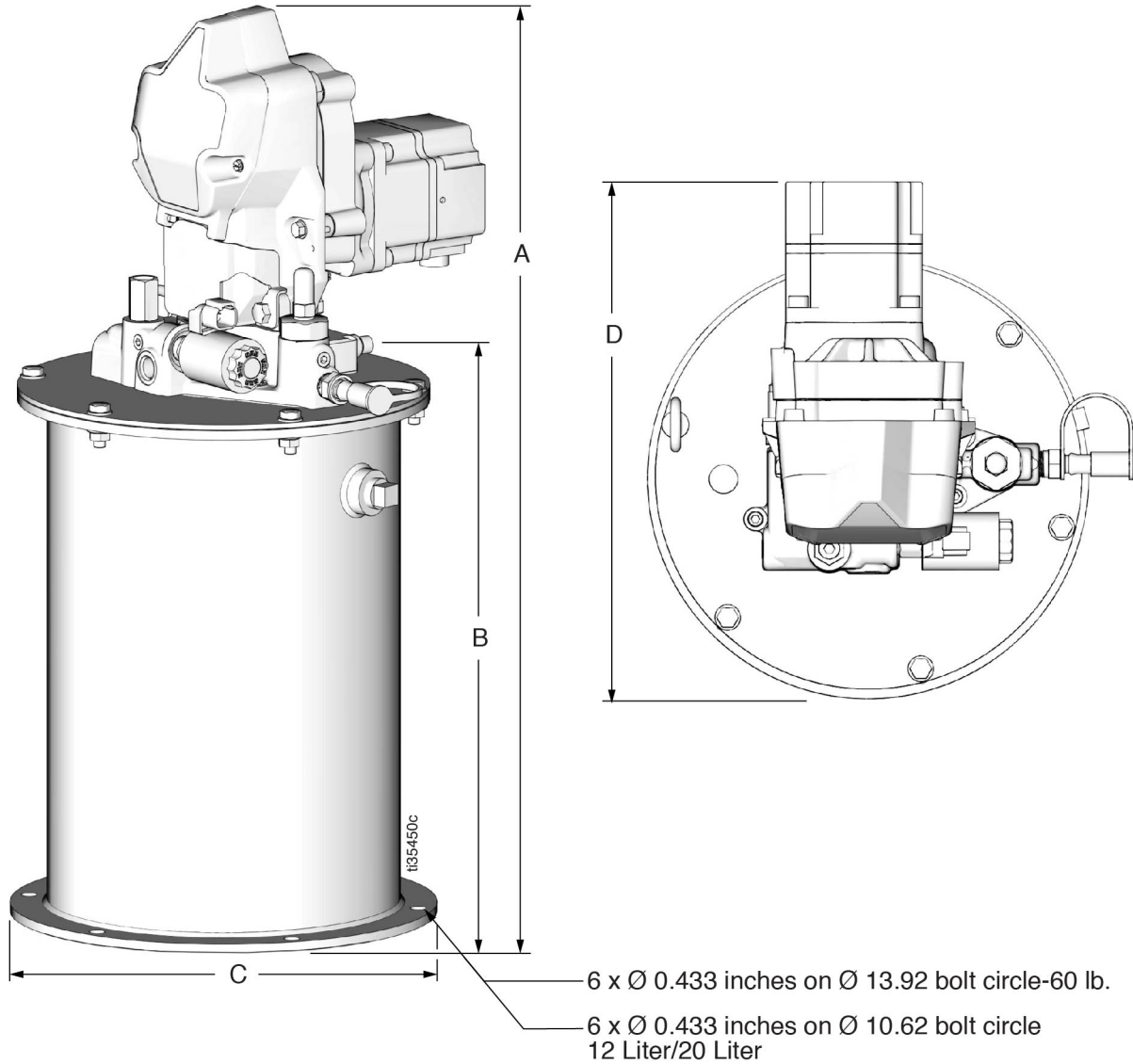

FIG. 82

Cable Harness Part Number (Included with the Pump Part Number*					
Motor	X	X	X	X	X
Vent Valve	X	X	--	X	--
Pressure Switch/Pressure Reporting	X	--	--	--	--
Level Switch/Level Reporting	X	X	X	--	--
Cable Harness Part Number	25P947	25R560	24N402, 126331 - one (1) each	24N402 - two (2) pieces	24N402
Refer Cable Manual Number	3A7035	3A7035	--	--	--
Pump Part Number Example	CD2324	CD1114	CD2021	CD1130	CD1030

**Pumps without tanks are not supplied with cable harness*

Dimensions: Pump with Tank



Ref	12 Liter		20 Liter		60 lb.	
	inches	mm	inches	mm	inches	mm
A	24.53	623.1	30.48	774.2	28.4	721.4
B	14.43	366.5	20.38	517.7	18.2	462.3
C	11.48	291.6	11.48	291.6	15.08	383.0
D	13.9	353.1	13.9	353.1	15.6	396.2

Dimensions: Stand Alone Pump

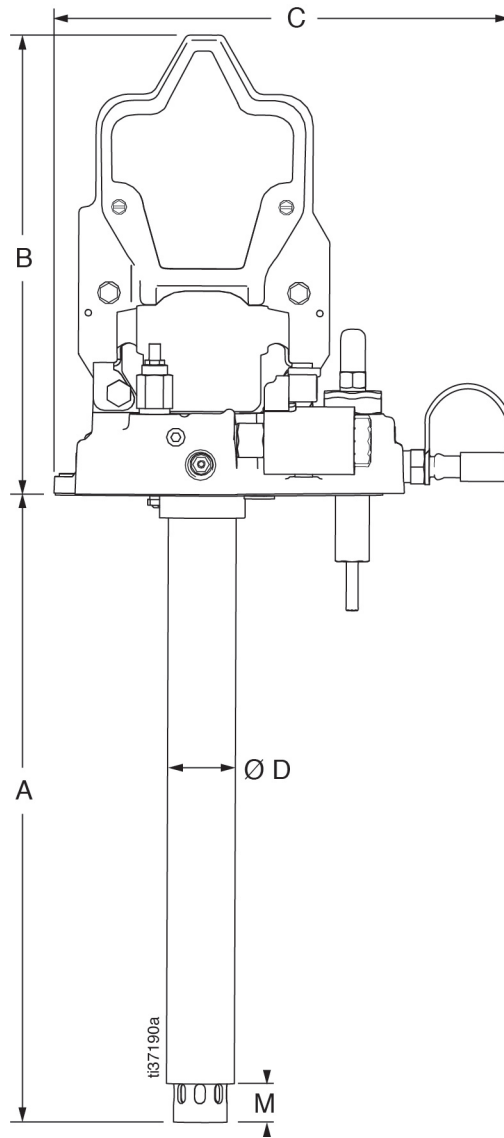

Ref	12 Liter		20 Liter		60 lb.	
	inches	mm	inches	mm	inches	mm
A	13.92	353.57	19.89	505.21	17.78	451.6
B	10.1	256.54	10.1	256.54	10.1	256.54
C	9.8	248.92	9.8	248.92	9.8	248.92
D	1.5	38.1	1.5	38.1	1.5	38.1
M	0.8	20.32	0.8	20.32	0.8	20.32

Dimensions: Stand Alone Pump

Top View

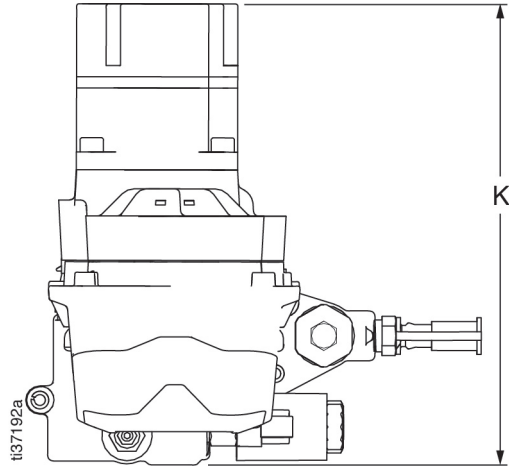

Bottom View

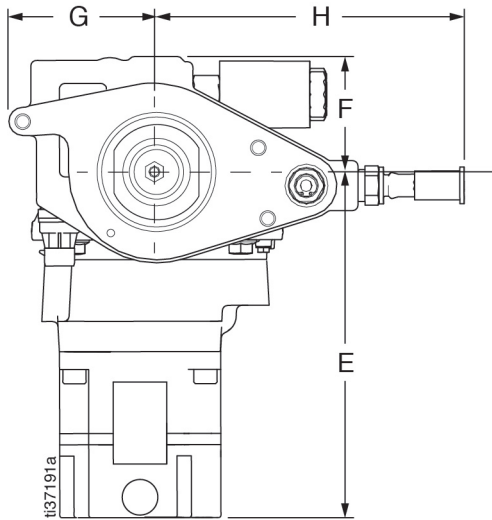

Ref	12 Liter/20 Liter/60 lb.	
	inches	mm
E	7.63	193.8
F	2.54	64.52
G	3.26	82.83
H	6.79	172.47
K	10.18	258.6

Technical Specifications

Compact Dyna-Star Electric Pump		
	US	Metric
Maximum working pressure	3500 psi	24.1 MPa, 241 bar
Pressure switch factory set:	3000 psi	20.7 MPa, 207 bar
Pressure relief valve factory set:	4000 psi	27.6 MPa, 276 bar
Operating Temperature	-40° F to 149° F	-40° C to 65° C
IP Rating	IP69K	
Electrical Requirements		
Voltage	24 VDC	
Input Voltage Range	18-30 VDC	
Maximum Current	10 A	
Peak Operating Current	15 A	
Maximum Delivery*	4.5 in ³ /min	74 cc/min
Grease Tank Capacity (Graco supplied)	12 or 20 Liters	
Inlet/Outlet Size		
Tank Fill Port	Quick Coupler	
Overflow Port	1/2 in. npt	
Fluid Outlet	3/8 in. npt	
Noise (dBa)		
Maximum sound pressure	<70 dBa	
Low Level Switch/Low Level Transducer		
Operating Voltage	0 - 30 VDC	
Output Type	1 Switching output, NO 1 Analog output 1 - 5V (pressure transducer)	
Connection Type	M12X1, 4-pin	
Pressure Switch/Pressure Transducer		
Operating Voltage	24 VDC	
Output Type	1 Switching output, NO 1 Analog output 1 - 5V (pressure transducer)	
Connection Type	Packard Metri-Pack 150 Series	
Pressure Switch/Pressure Transducer		
Pump	steel, buna-N, acetal, lubrithane, polyurethane, brass, polyethylene	
Tank	steel, buna-N, rubber, aluminum	
Weight - Without Grease in the Tank		
12 Liter	66 lb	29.9 kg
20 Liter	73 lb	33.1 kg
60 lb.	83 lb	37.6 kg
Weight - Pump Only		
12 Liter	25 lb	11.3 kg
20 Liter	30 lb	13.6 kg
60 lb.	27 lb.	12.2 kg
*Output of the pump depends upon the fluid being used, the output pressure, the ambient temperature, and other environmental factors.		

California Proposition 65

CALIFORNIA RESIDENTS

 **WARNING:** Cancer and reproductive harm – www.P65warnings.ca.gov.

Graco Standard Warranty

Graco warrants all equipment referenced in this document which is manufactured by Graco and bearing its name to be free from defects in material and workmanship on the date of sale to the original purchaser for use. With the exception of any special, extended, or limited warranty published by Graco, Graco will, for a period of twelve months from the date of sale, repair or replace any part of the equipment determined by Graco to be defective. This warranty applies only when the equipment is installed, operated and maintained in accordance with Graco's written recommendations.

This warranty does not cover, and Graco shall not be liable for general wear and tear, or any malfunction, damage or wear caused by faulty installation, misapplication, abrasion, corrosion, inadequate or improper maintenance, negligence, accident, tampering, or substitution of non-Graco component parts. Nor shall Graco be liable for malfunction, damage or wear caused by the incompatibility of Graco equipment with structures, accessories, equipment or materials not supplied by Graco, or the improper design, manufacture, installation, operation or maintenance of structures, accessories, equipment or materials not supplied by Graco.

This warranty is conditioned upon the prepaid return of the equipment claimed to be defective to an authorized Graco distributor for verification of the claimed defect. If the claimed defect is verified, Graco will repair or replace free of charge any defective parts. The equipment will be returned to the original purchaser transportation prepaid. If inspection of the equipment does not disclose any defect in material or workmanship, repairs will be made at a reasonable charge, which charges may include the costs of parts, labor, and transportation.

THIS WARRANTY IS EXCLUSIVE, AND IS IN LIEU OF ANY OTHER WARRANTIES, EXPRESS OR IMPLIED, INCLUDING BUT NOT LIMITED TO WARRANTY OF MERCHANTABILITY OR WARRANTY OF FITNESS FOR A PARTICULAR PURPOSE.

Graco's sole obligation and buyer's sole remedy for any breach of warranty shall be as set forth above. The buyer agrees that no other remedy (including, but not limited to, incidental or consequential damages for lost profits, lost sales, injury to person or property, or any other incidental or consequential loss) shall be available. Any action for breach of warranty must be brought within two (2) years of the date of sale.

GRACO MAKES NO WARRANTY, AND DISCLAIMS ALL IMPLIED WARRANTIES OF MERCHANTABILITY AND FITNESS FOR A PARTICULAR PURPOSE, IN CONNECTION WITH ACCESSORIES, EQUIPMENT, MATERIALS OR COMPONENTS SOLD BUT NOT MANUFACTURED BY GRACO. These items sold, but not manufactured by Graco (such as electric motors, switches, hose, etc.), are subject to the warranty, if any, of their manufacturer. Graco will provide purchaser with reasonable assistance in making any claim for breach of these warranties.

In no event will Graco be liable for indirect, incidental, special or consequential damages resulting from Graco supplying equipment hereunder, or the furnishing, performance, or use of any products or other goods sold hereto, whether due to a breach of contract, breach of warranty, the negligence of Graco, or otherwise.

FOR GRACO CANADA CUSTOMERS

The Parties acknowledge that they have required that the present document, as well as all documents, notices and legal proceedings entered into, given or instituted pursuant hereto or relating directly or indirectly hereto, be drawn up in English. Les parties reconnaissent avoir convenu que la rédaction du présente document sera en Anglais, ainsi que tous documents, avis et procédures judiciaires exécutés, donnés ou intentés, à la suite de ou en rapport, directement ou indirectement, avec les procédures concernées.

Graco Information

For the latest information about Graco products, visit www.graco.com.

For patent information, see www.graco.com/patents.

TO PLACE AN ORDER, contact your Graco distributor or call to identify the nearest distributor.

Phone: 612-623-6928 **or Toll Free:** 1-800-533-9655, **Fax:** 612-378-3590

All written and visual data contained in this document reflects the latest product information available at the time of publication. Graco reserves the right to make changes at any time without notice.

Original instructions. This manual contains English. MM 3A6941

Graco Headquarters: Minneapolis

International Offices: Belgium, China, Japan, Korea

GRACO INC. AND SUBSIDIARIES • P.O. BOX 1441 • MINNEAPOLIS MN 55440-1441 • USA
Copyright 2019, Graco Inc. All Graco manufacturing locations are registered to ISO 9001.

www.graco.com
Revision L, April 2022